



US 20210231498A1

(19) **United States**

(12) **Patent Application Publication**
TUFILLARO et al.

(10) **Pub. No.: US 2021/0231498 A1**

(43) **Pub. Date: Jul. 29, 2021**

(54) **HYPERSPECTRAL SENSING SYSTEM AND
PROCESSING METHODS FOR
HYPERSPECTRAL DATA**

Publication Classification

(71) Applicant: **Flying Gybe Inc.**, Corvallis, OR (US)

(51) **Int. Cl.**
G01J 3/28 (2006.01)
G01J 3/02 (2006.01)
G01J 3/40 (2006.01)

(72) Inventors: **Nicholas TUFILLARO**, Corvallis, OR (US); **Ivan LALOVIC**, Portland, OR (US); **Omar ZURITA**, San Diego, CA (US)

(52) **U.S. Cl.**
CPC **G01J 3/2823** (2013.01); **G01J 3/0264** (2013.01); **G01J 2003/2826** (2013.01); **G01J 2003/2866** (2013.01); **G01J 3/40** (2013.01)

(21) Appl. No.: **17/230,431**

(57) **ABSTRACT**

(22) Filed: **Apr. 14, 2021**

A hyperspectral sensing device may include an optical collector configured to collect light and to transfer the collected light to a sensor having spectral resolution sufficient for sensing hyperspectral data. In some examples, the sensor comprises a compact spectrometer. The device further comprises a power supply, an electronics module, and an input/output hub enabling the device to transmit acquired data (e.g., to a remote server). In some examples, a plurality of hyperspectral sensing devices are deployed as a network to acquire data over a relatively large area. Methods are disclosed for performing dark-current calibration and/or radiometric calibration on data obtained by the hyperspectral sensing device, and/or another suitable device. Data obtained by the device may be represented in a functional basis space, enabling computations that utilize all of the hyperspectral data without loss of information.

Related U.S. Application Data

(60) Division of application No. 16/583,042, filed on Sep. 25, 2019, which is a continuation-in-part of application No. 16/366,635, filed on Mar. 27, 2019, now Pat. No. 10,794,888.

(60) Provisional application No. 62/648,779, filed on Mar. 27, 2018.

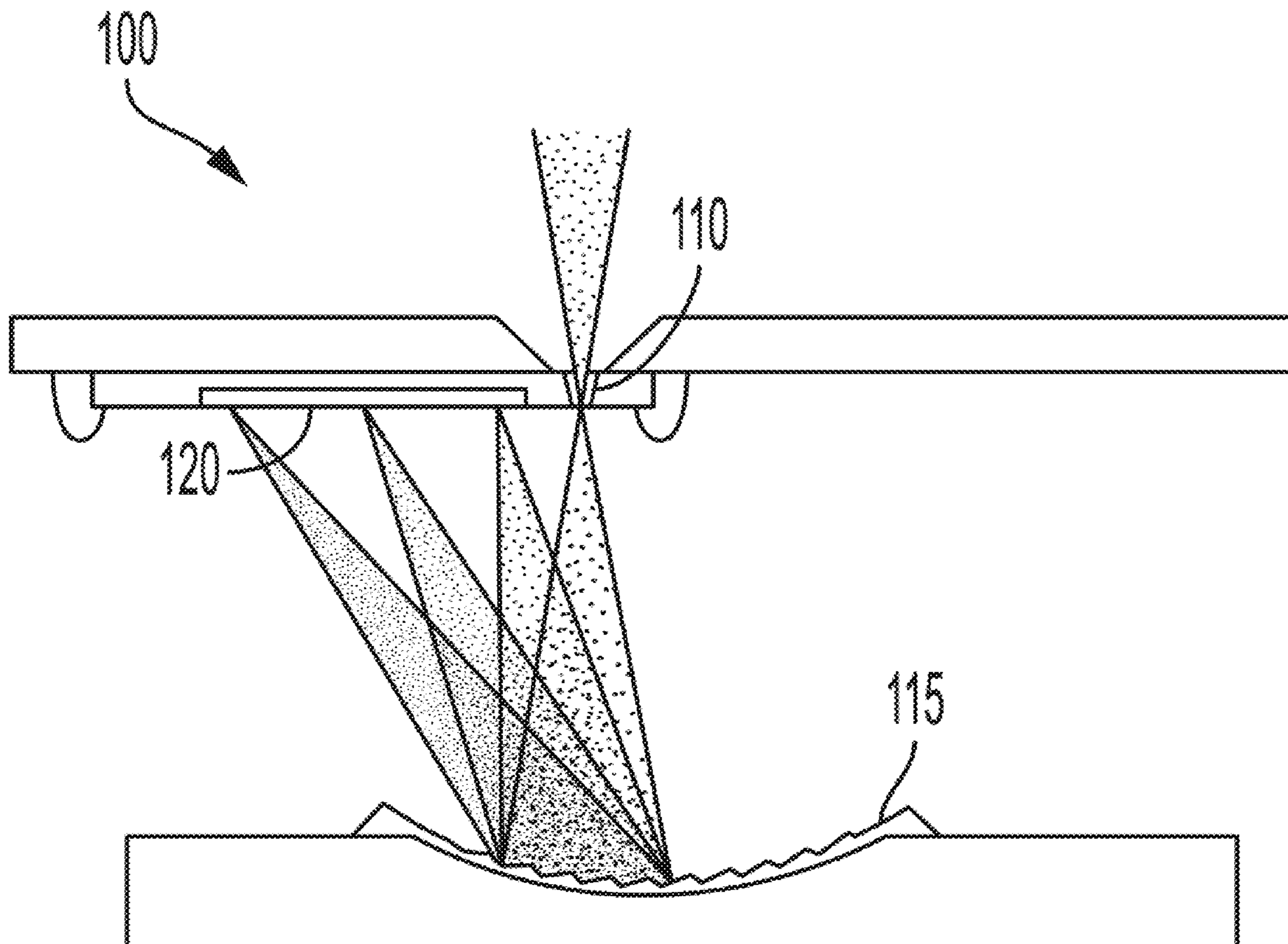

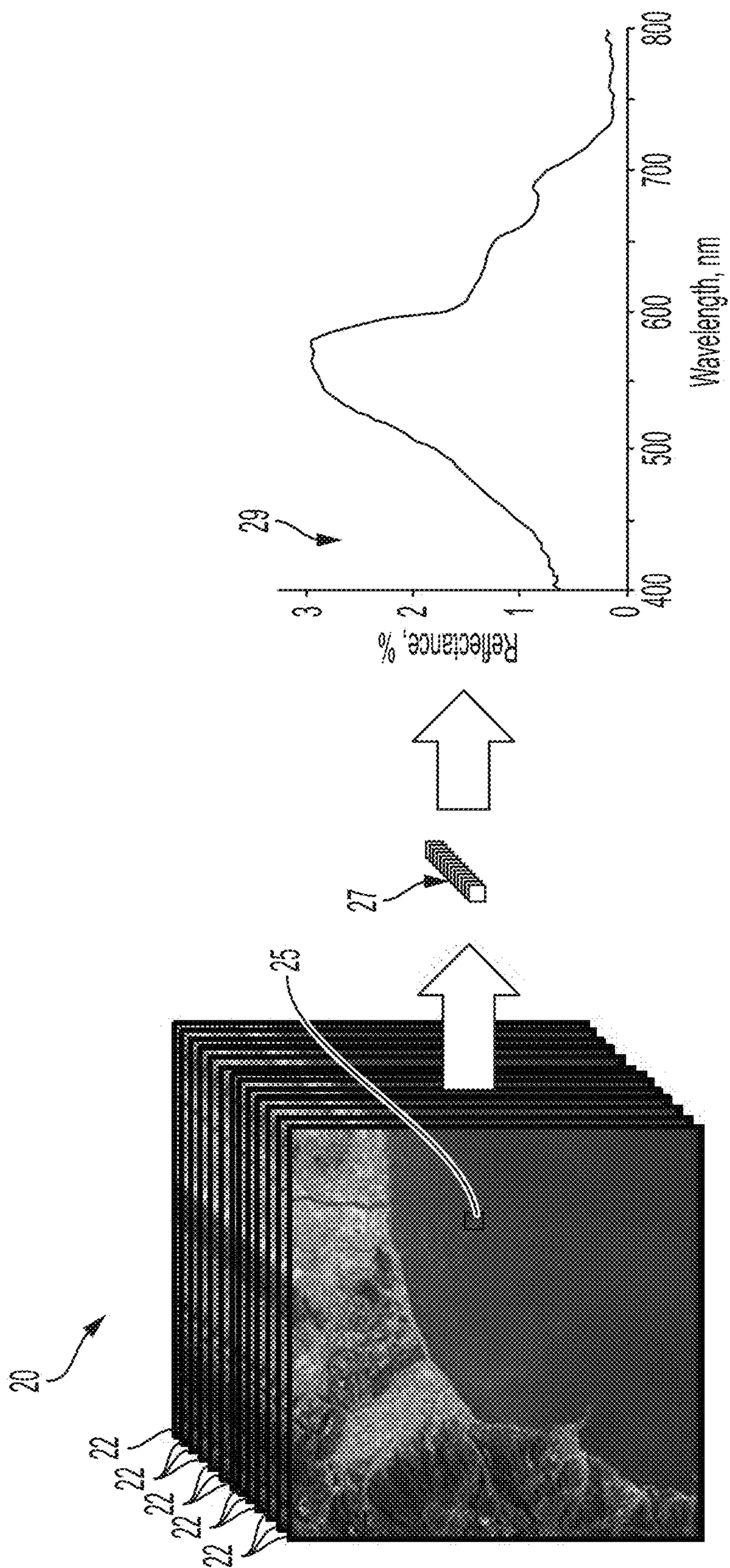

FIG. 1

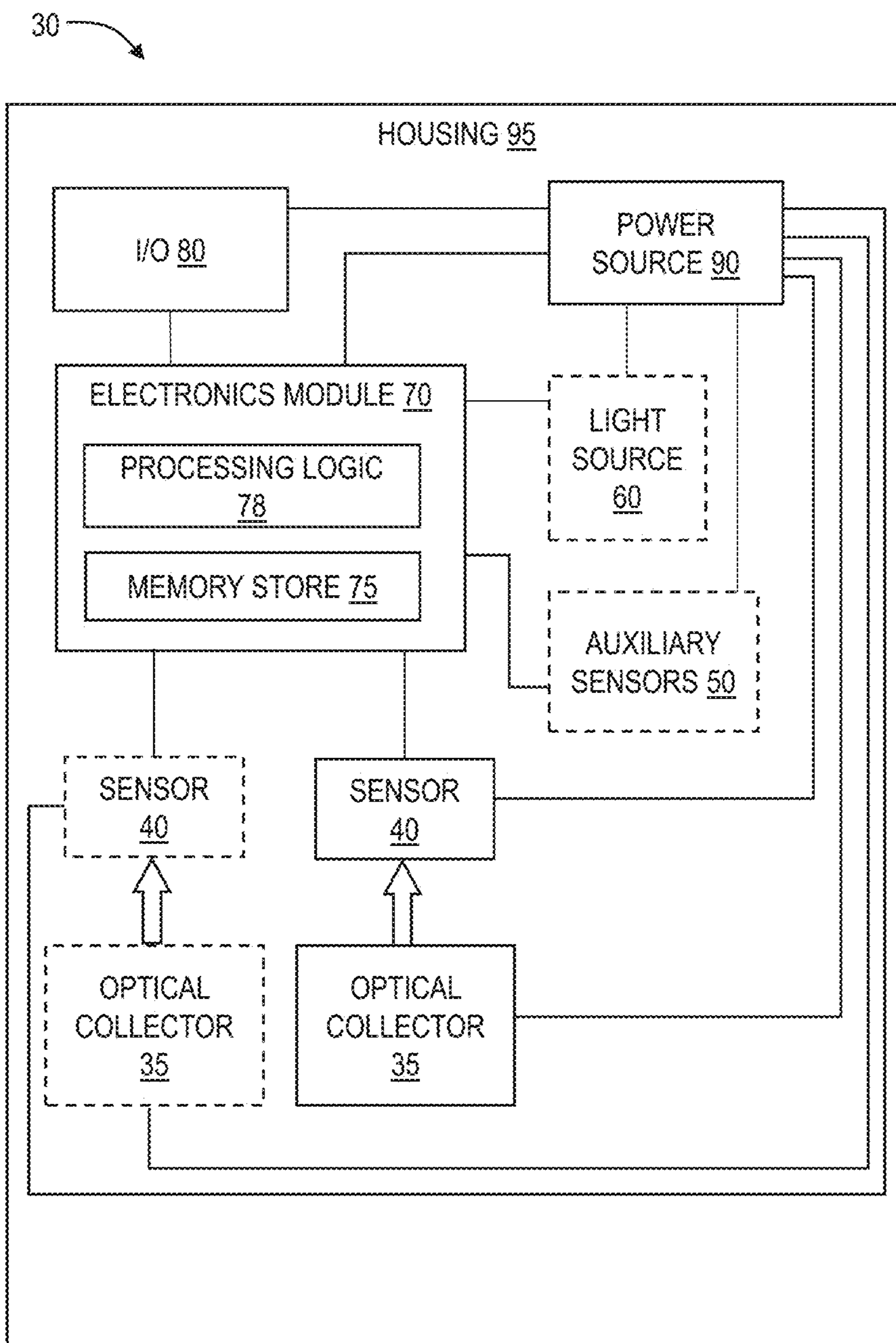

FIG. 2

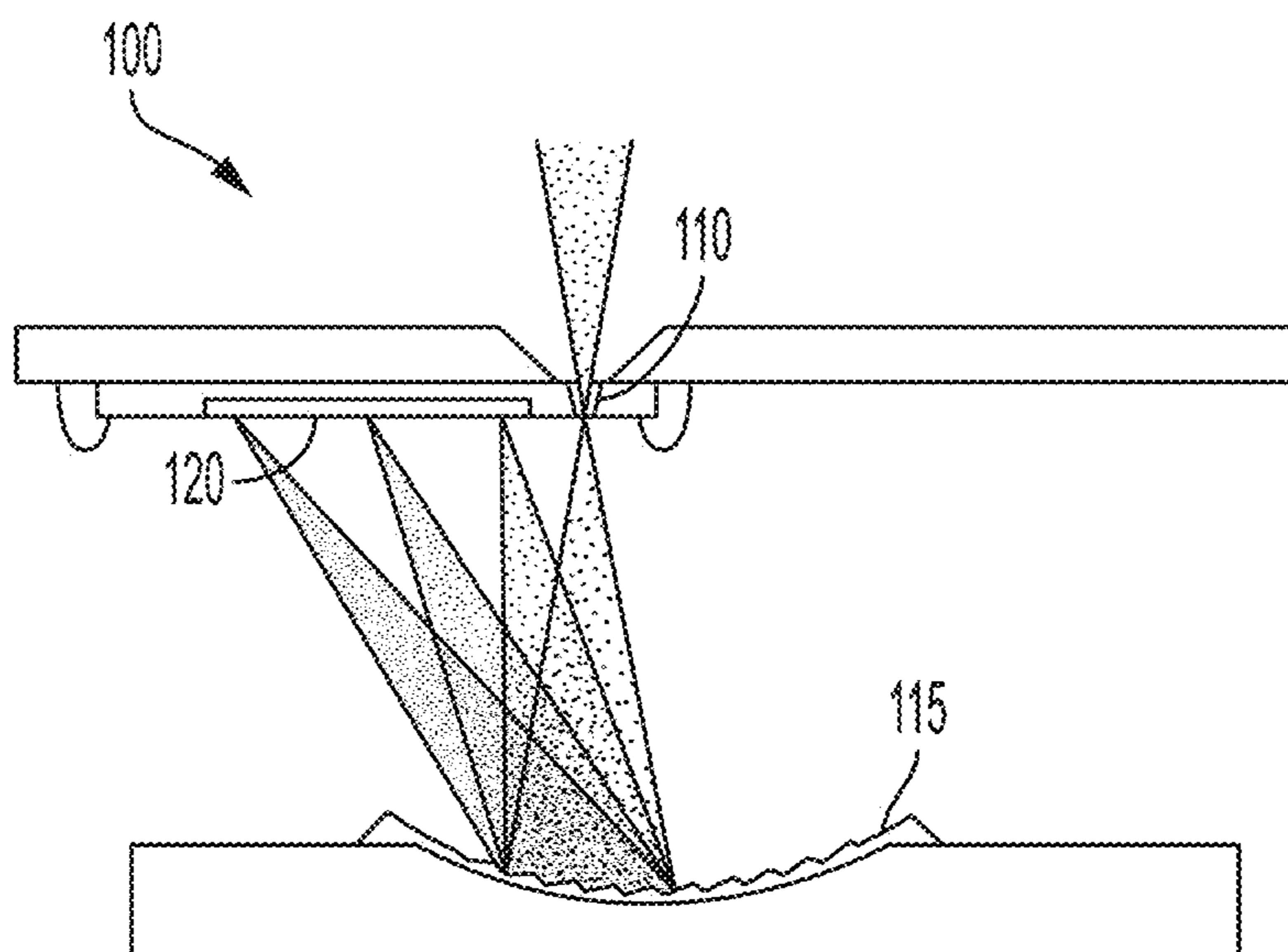

FIG. 3

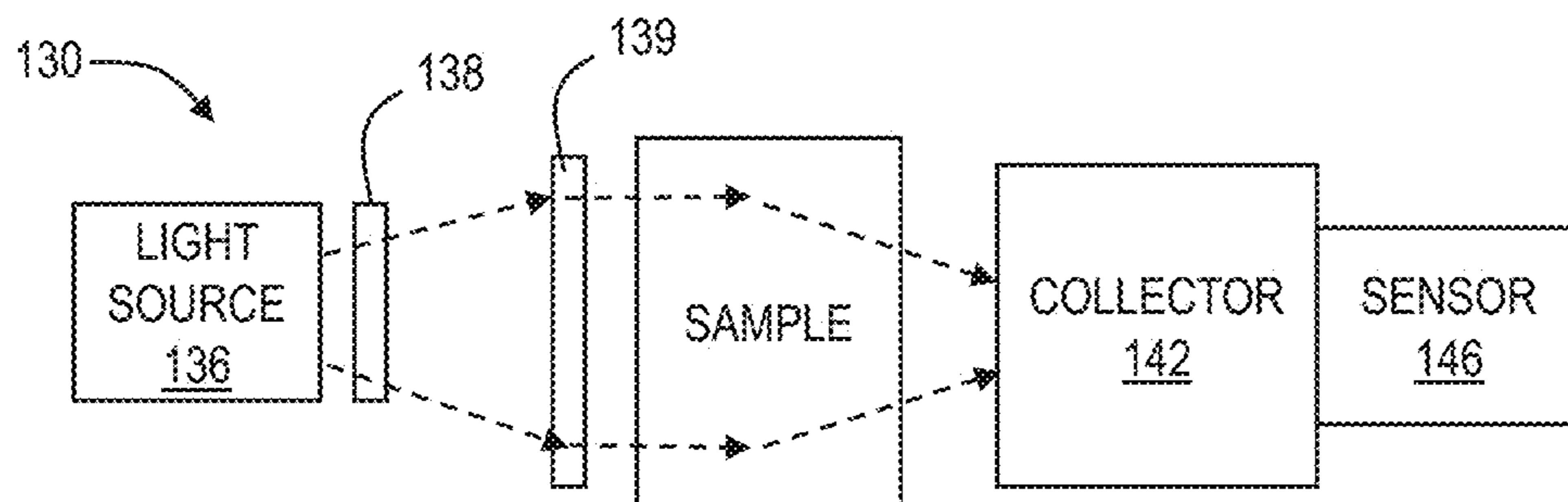

FIG. 4

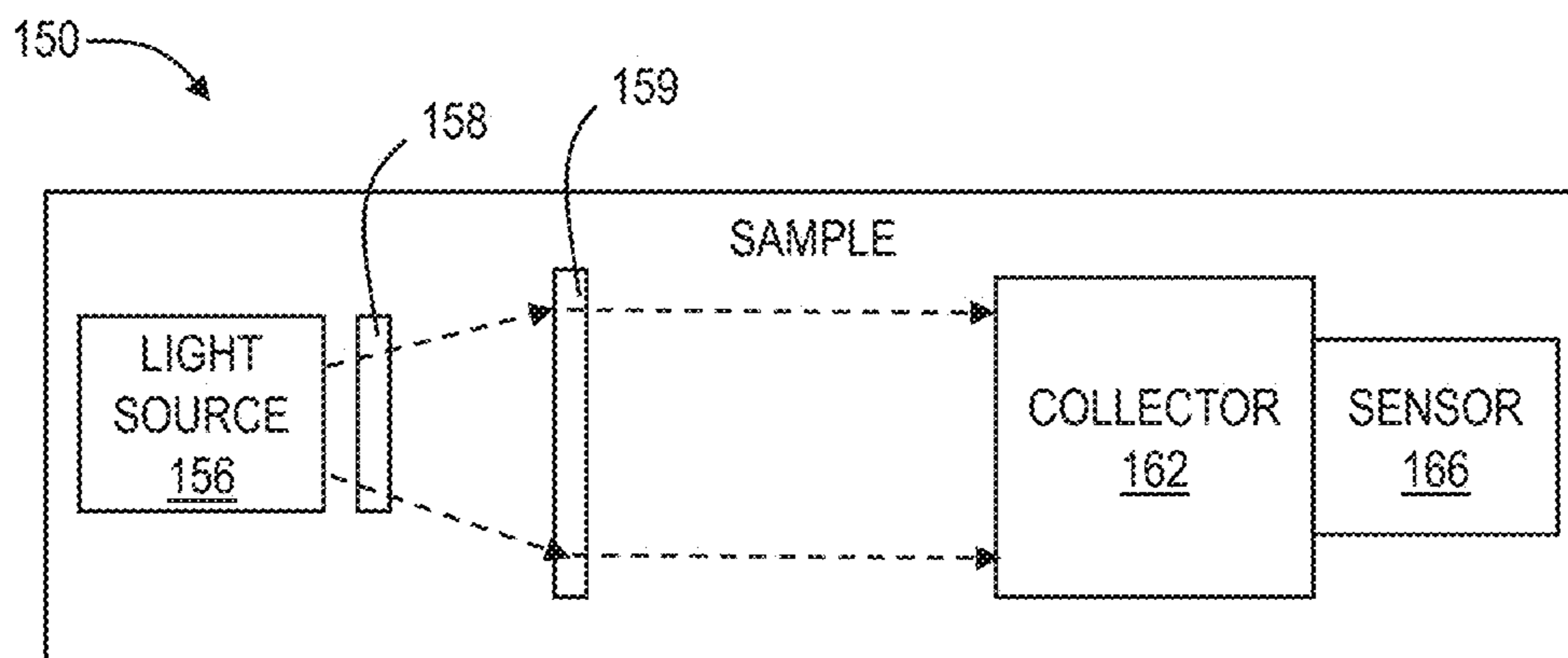

FIG. 5

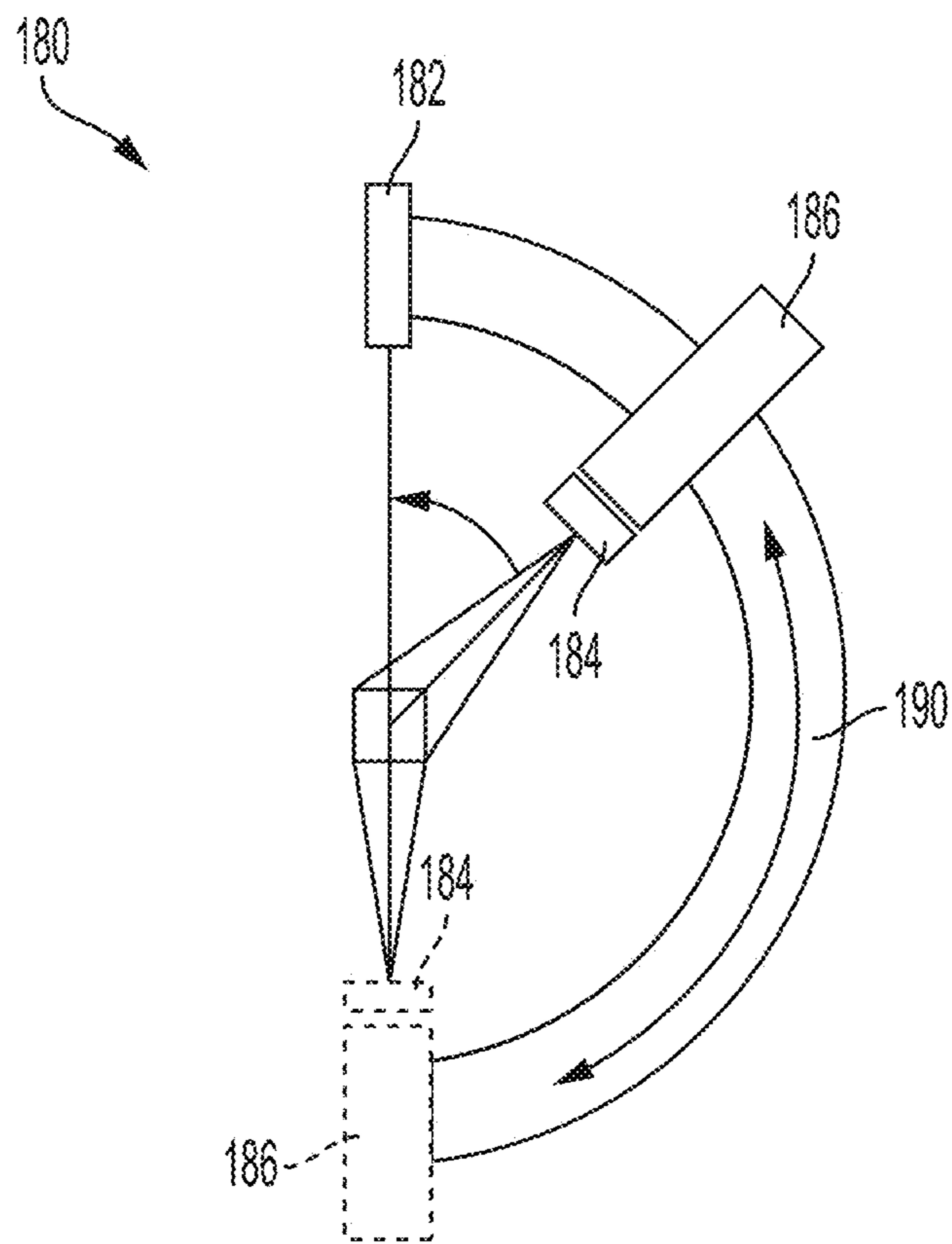

FIG. 6

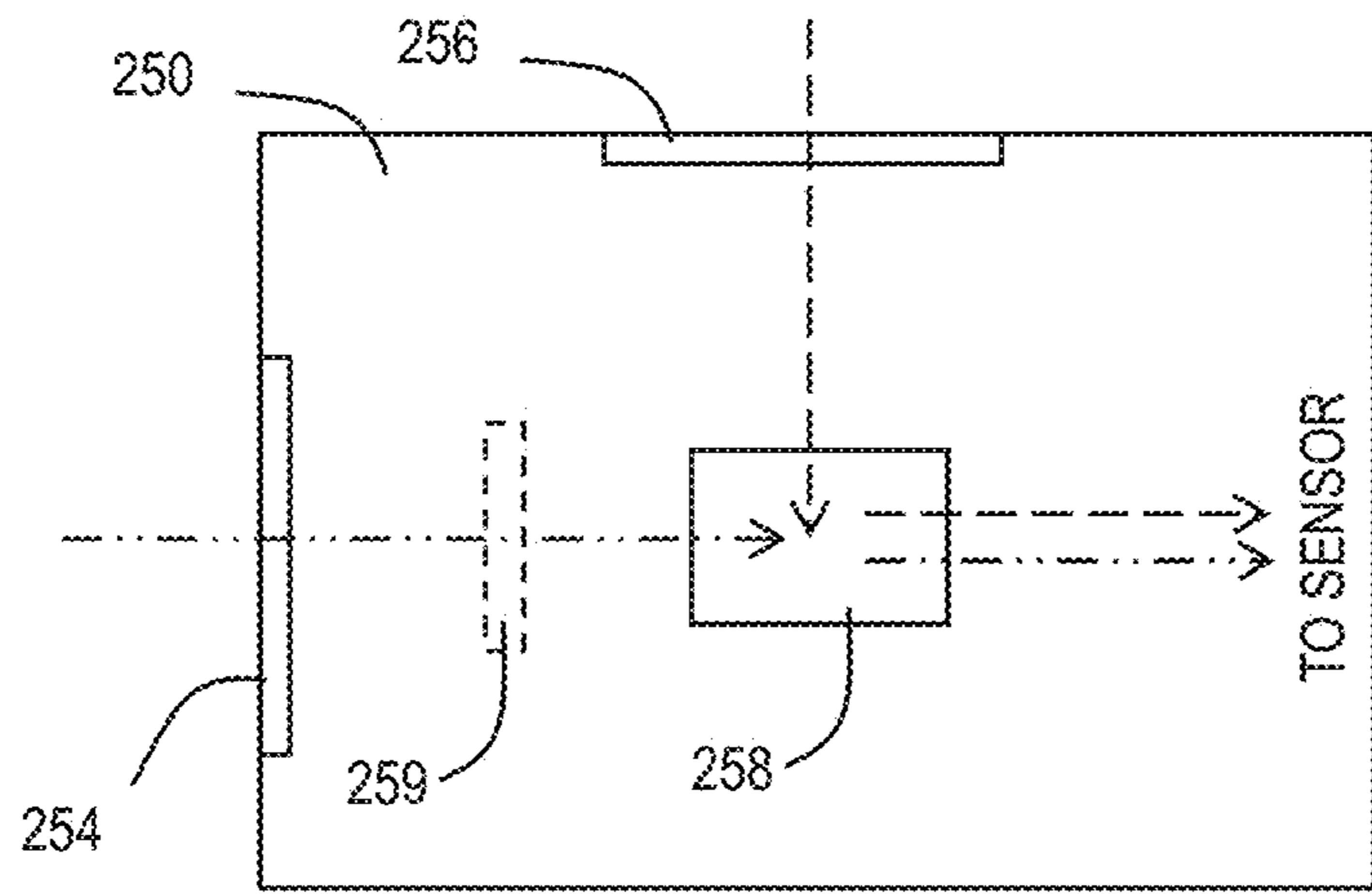

FIG. 7

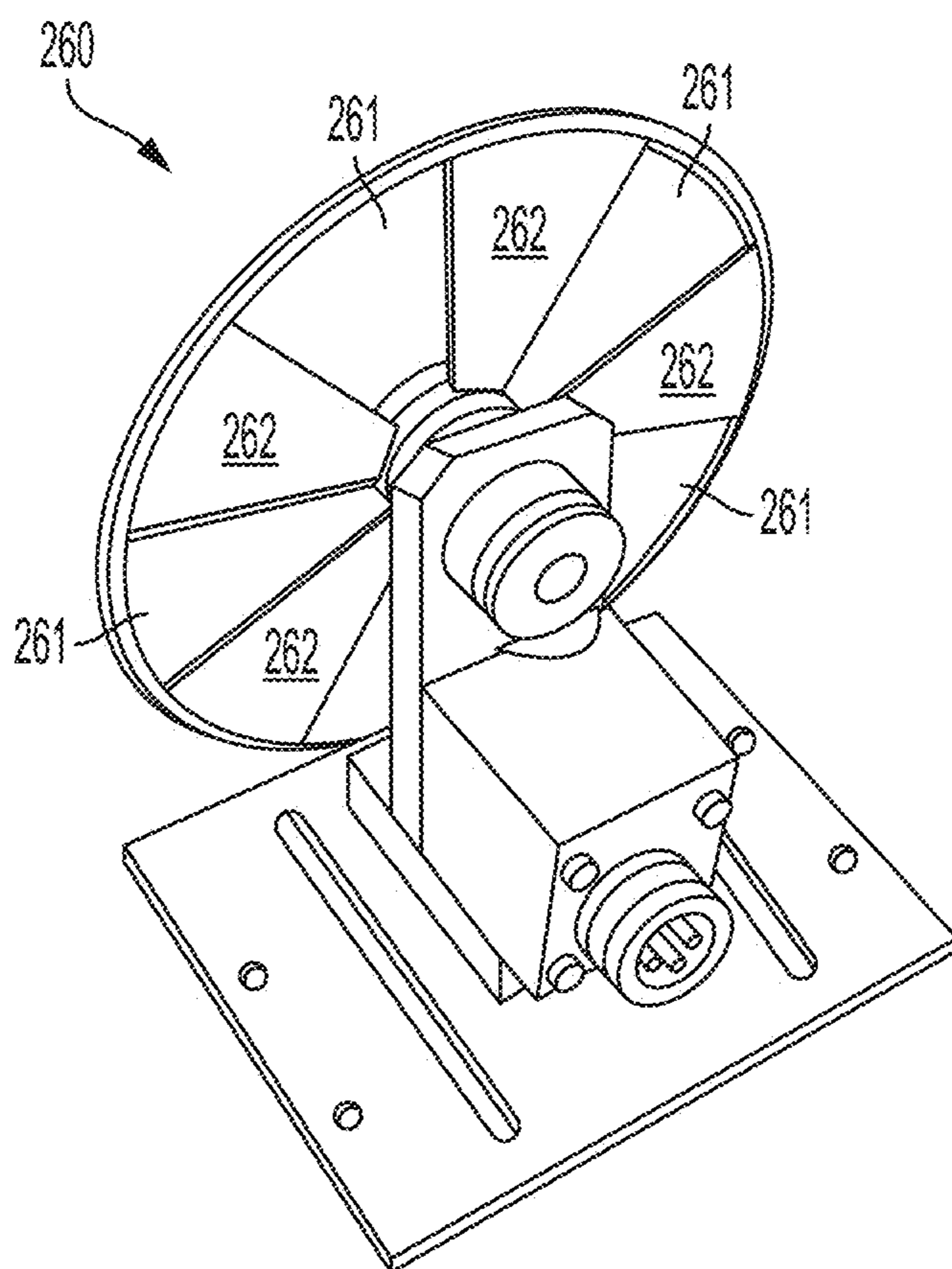

FIG. 8

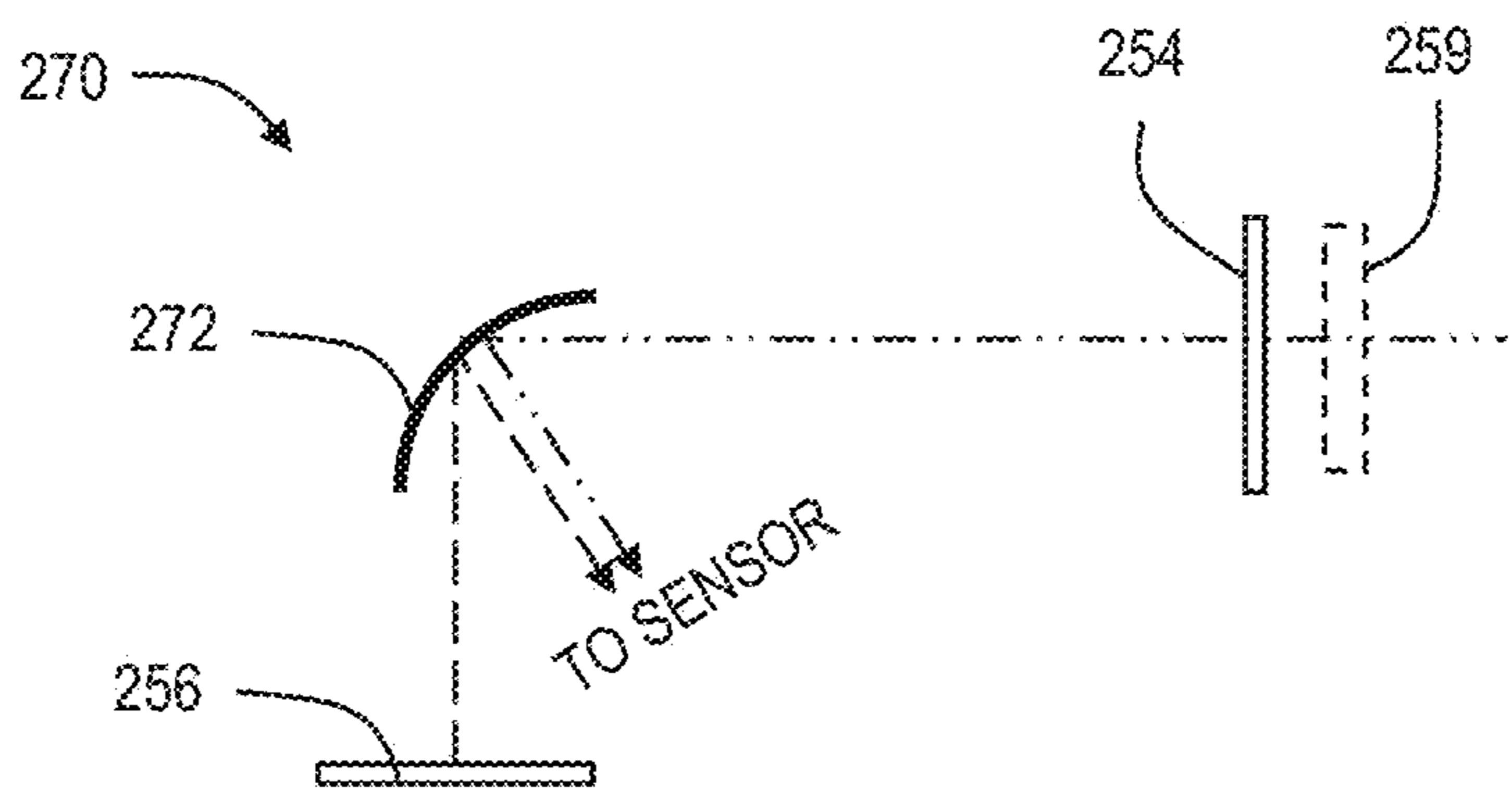

FIG. 9

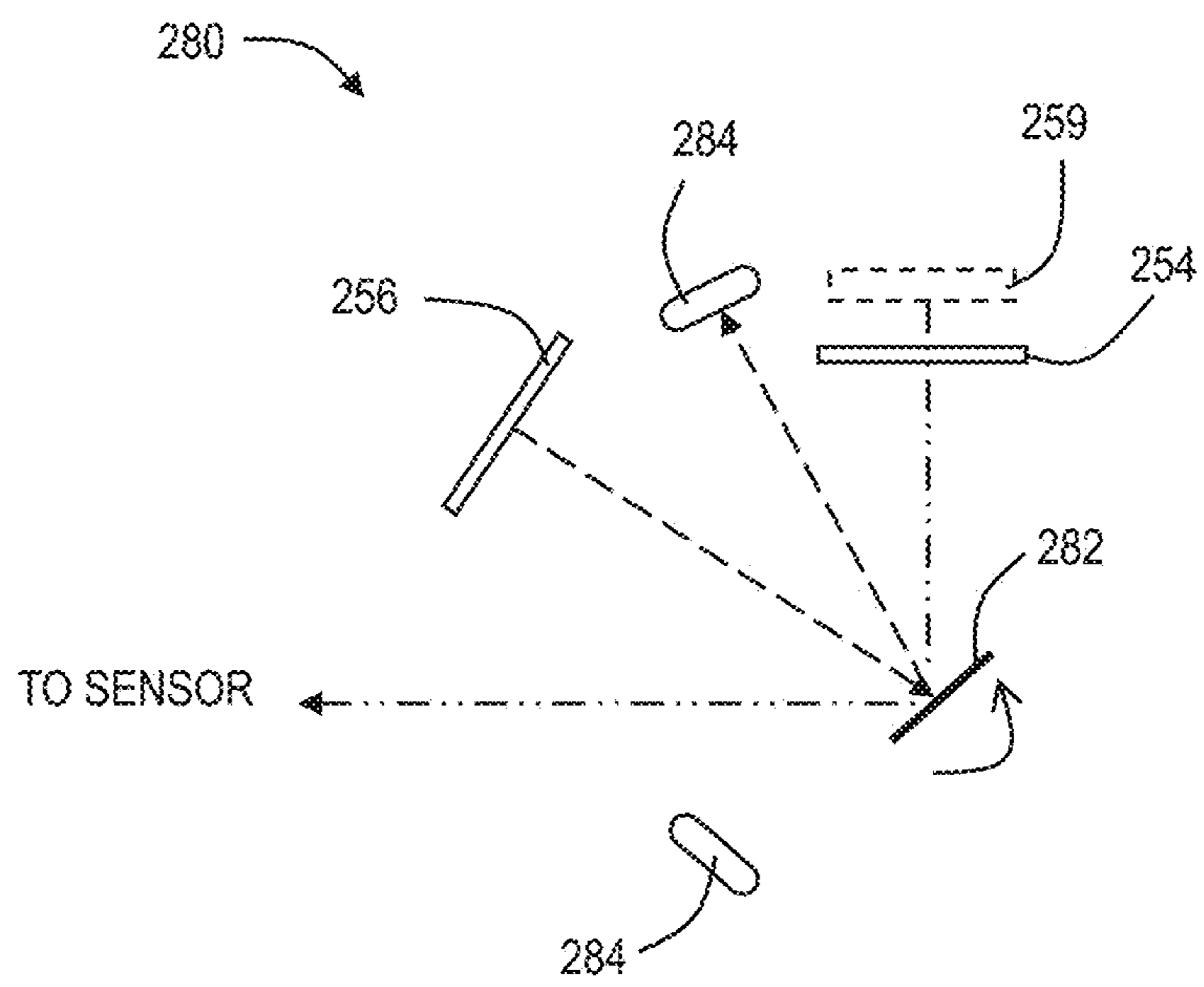

FIG. 10

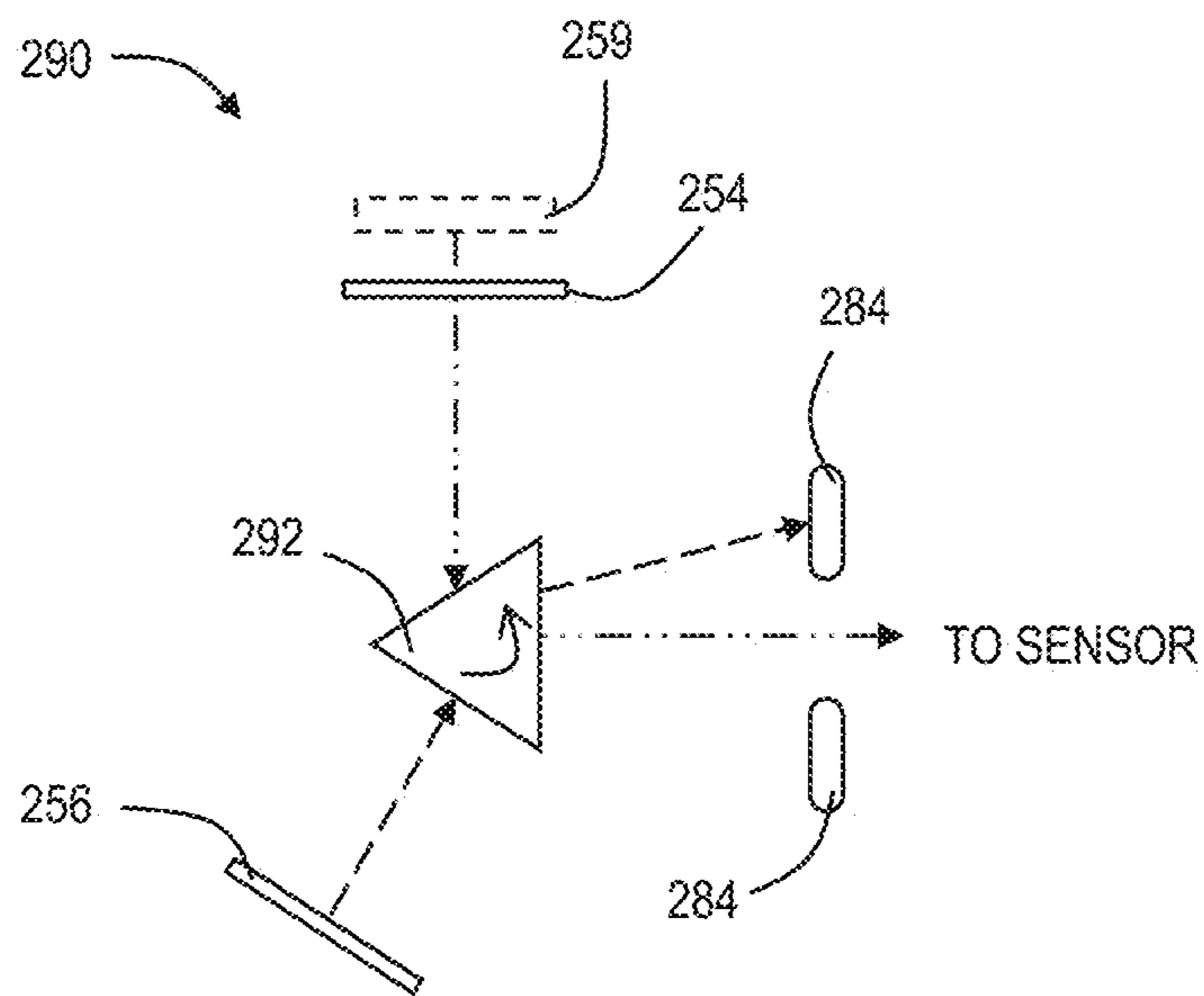

FIG. 11

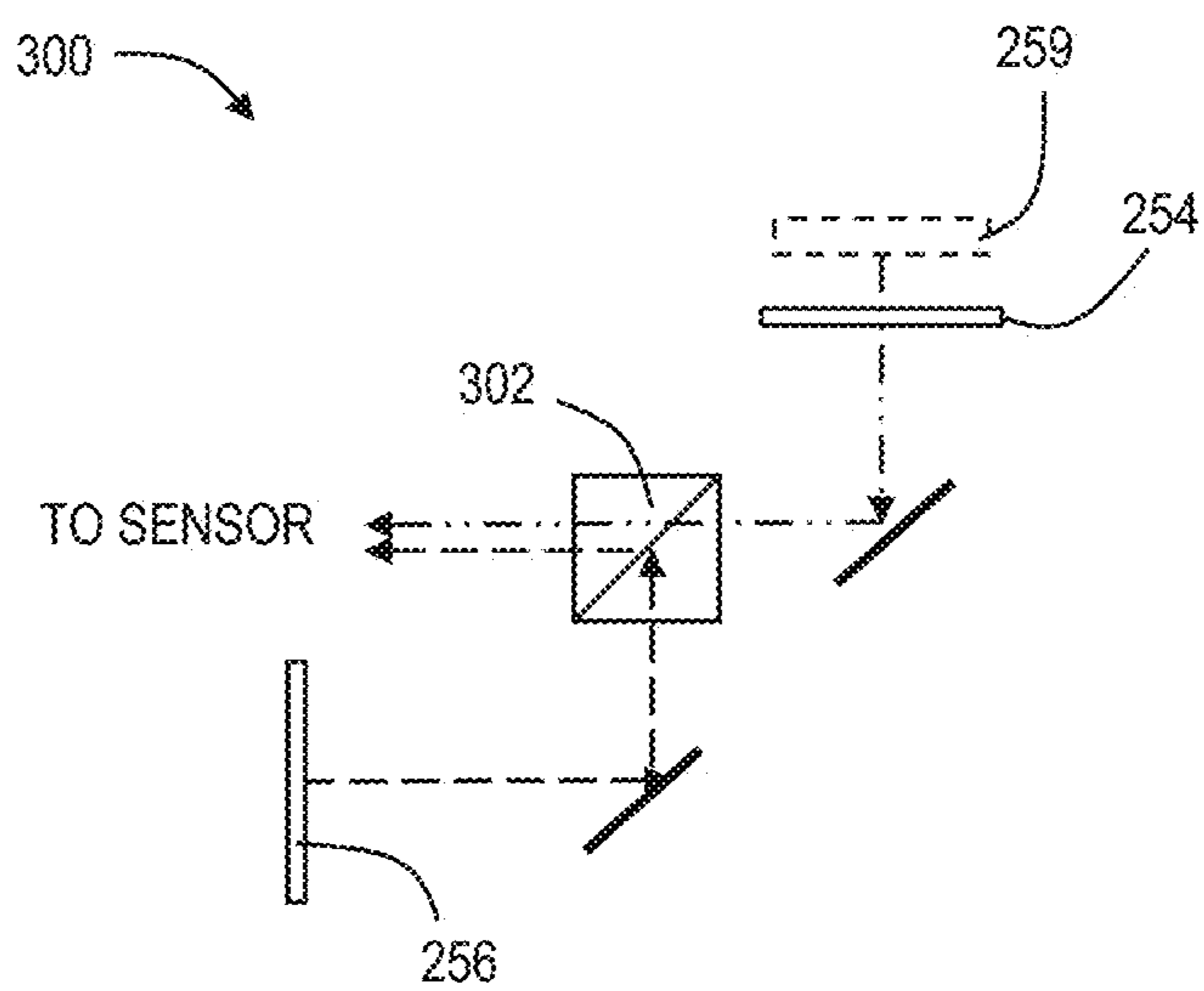

FIG. 12

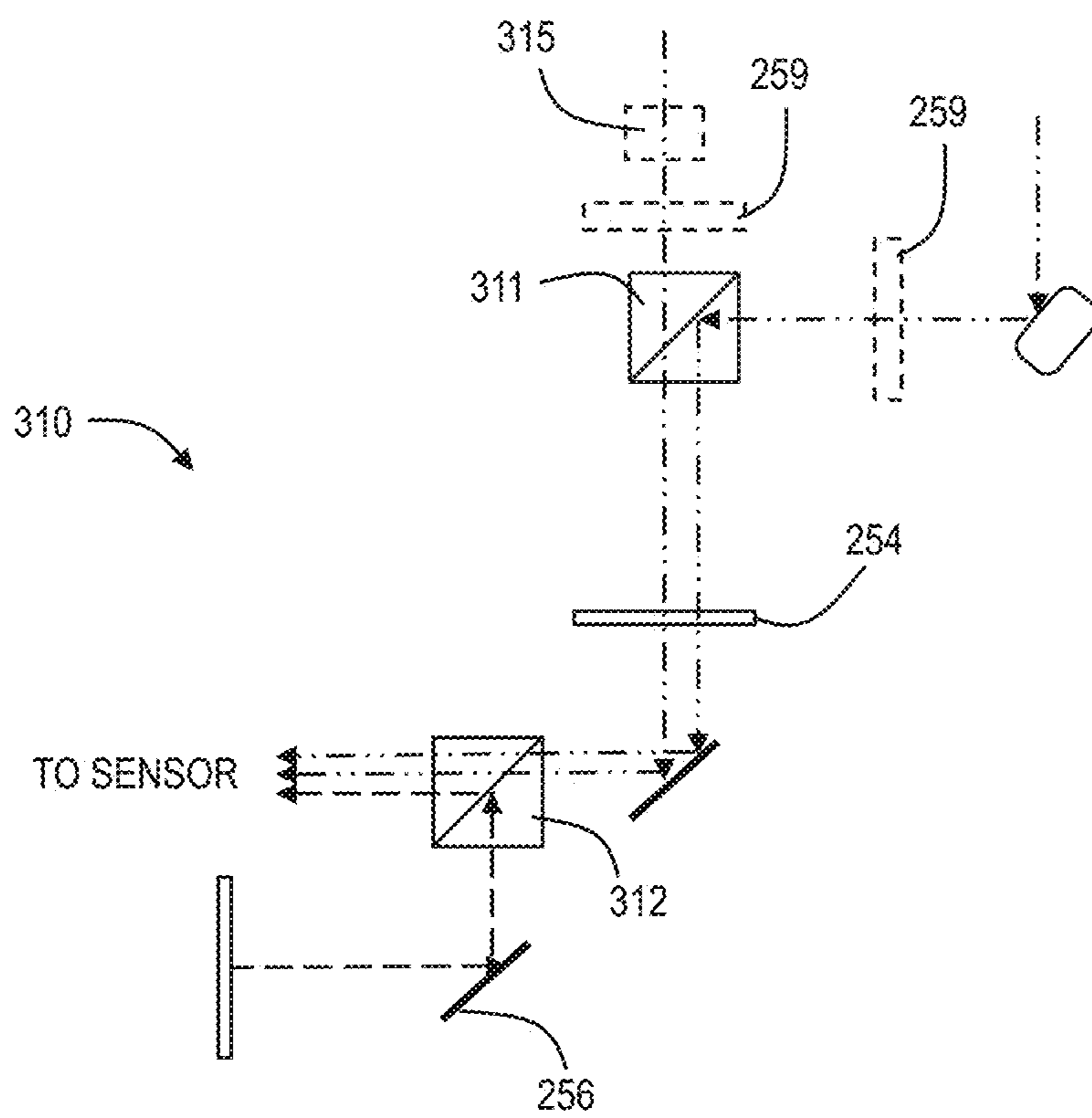

FIG. 13

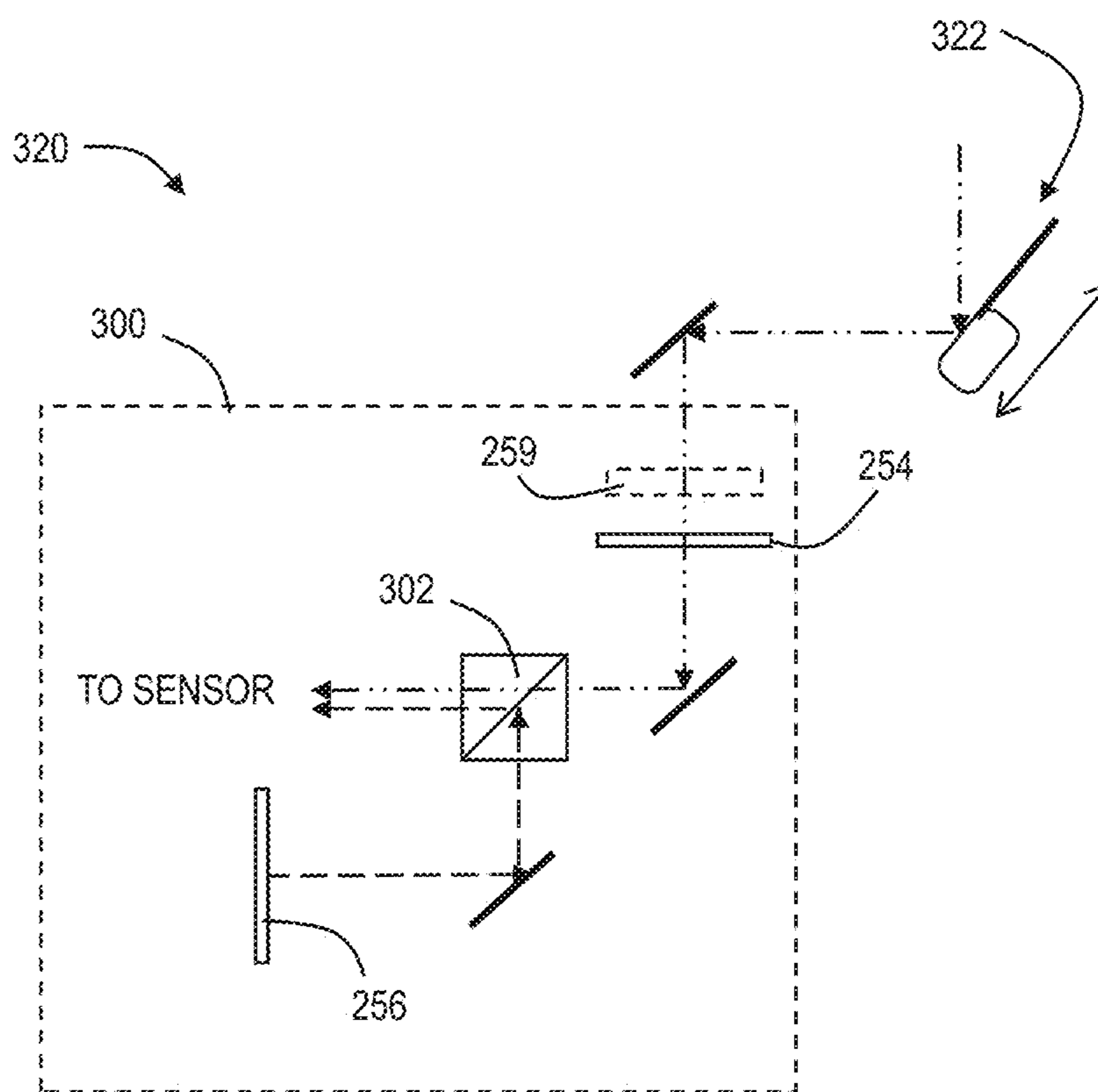

FIG. 14

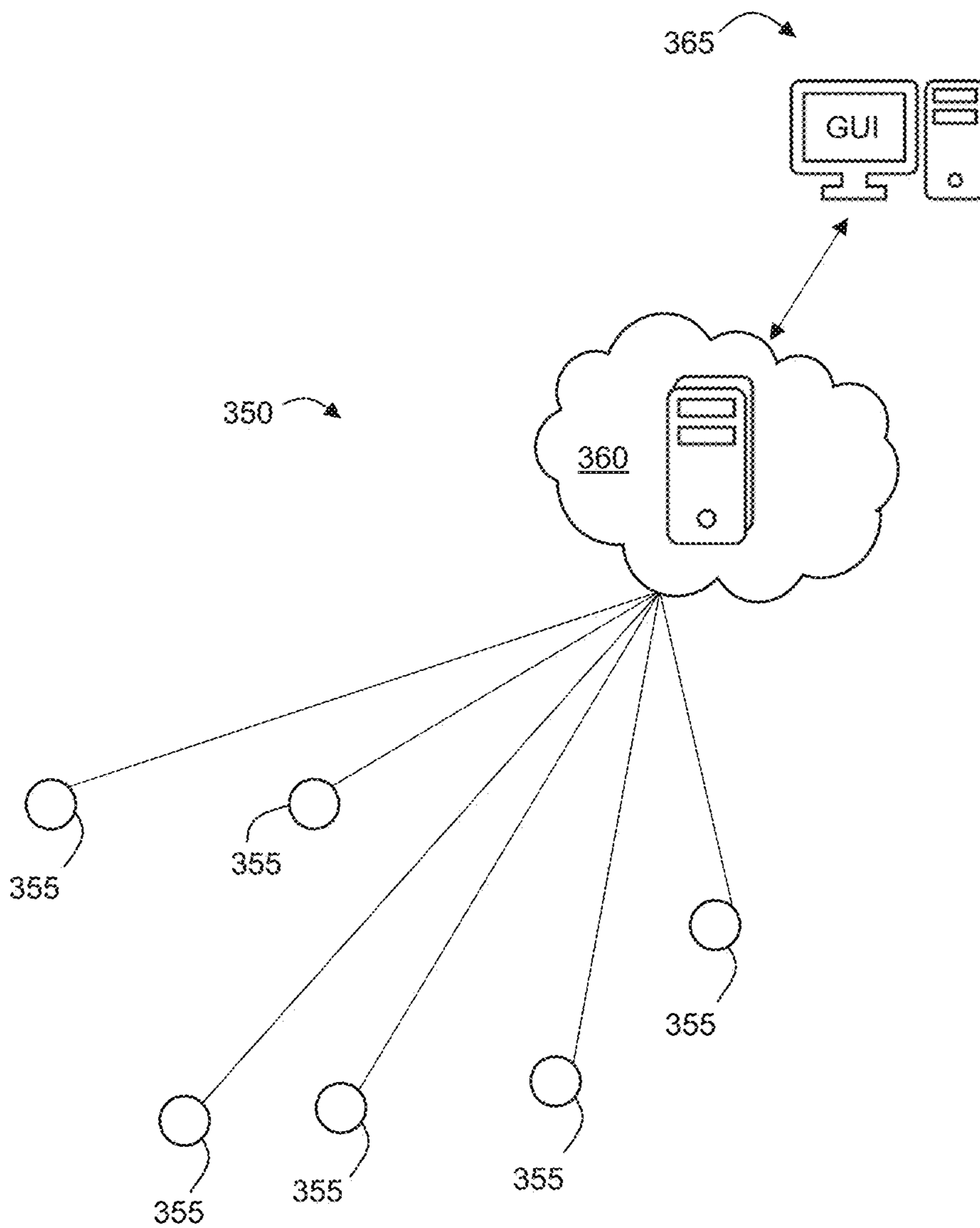

FIG. 15

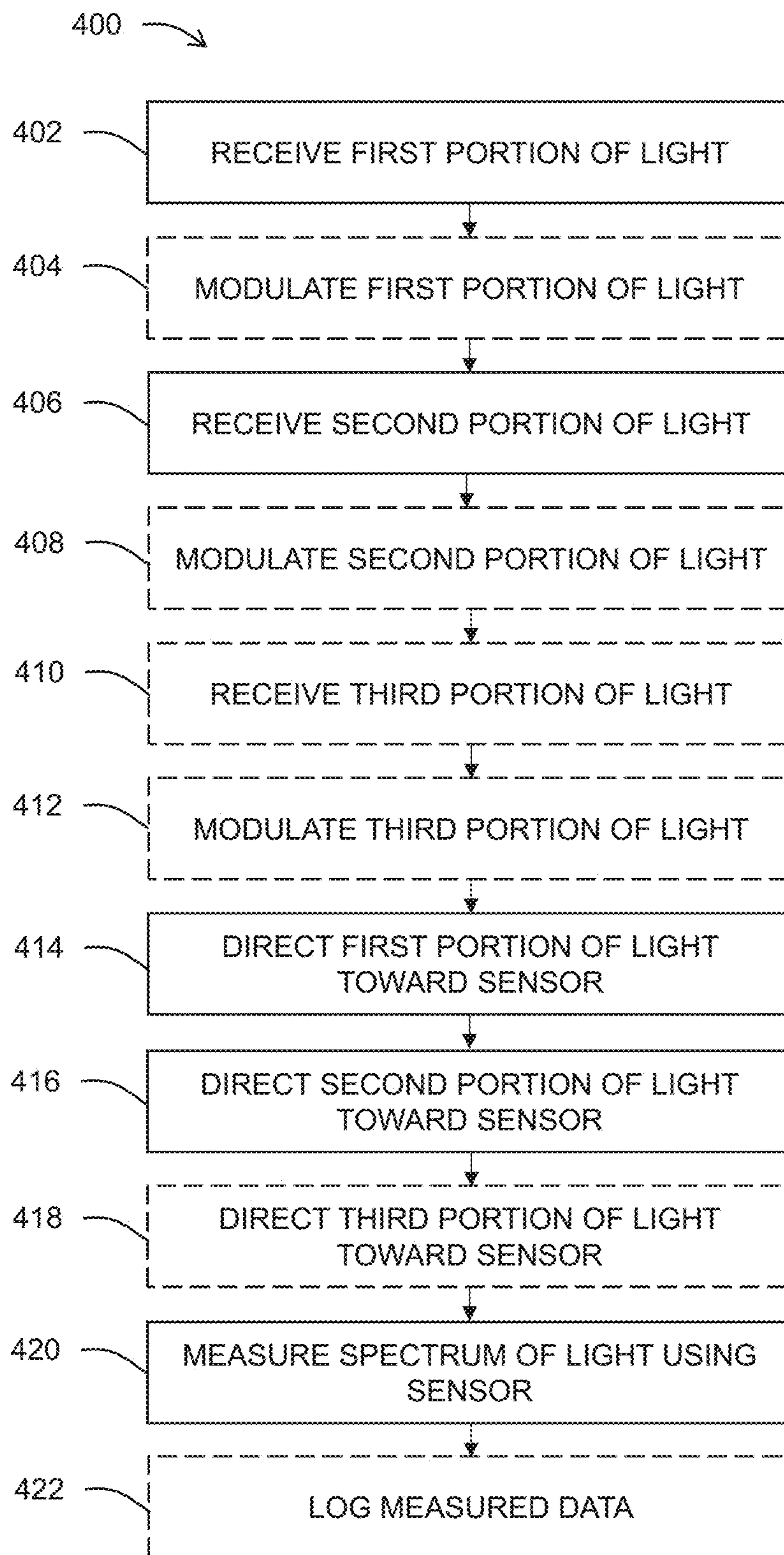

FIG. 16

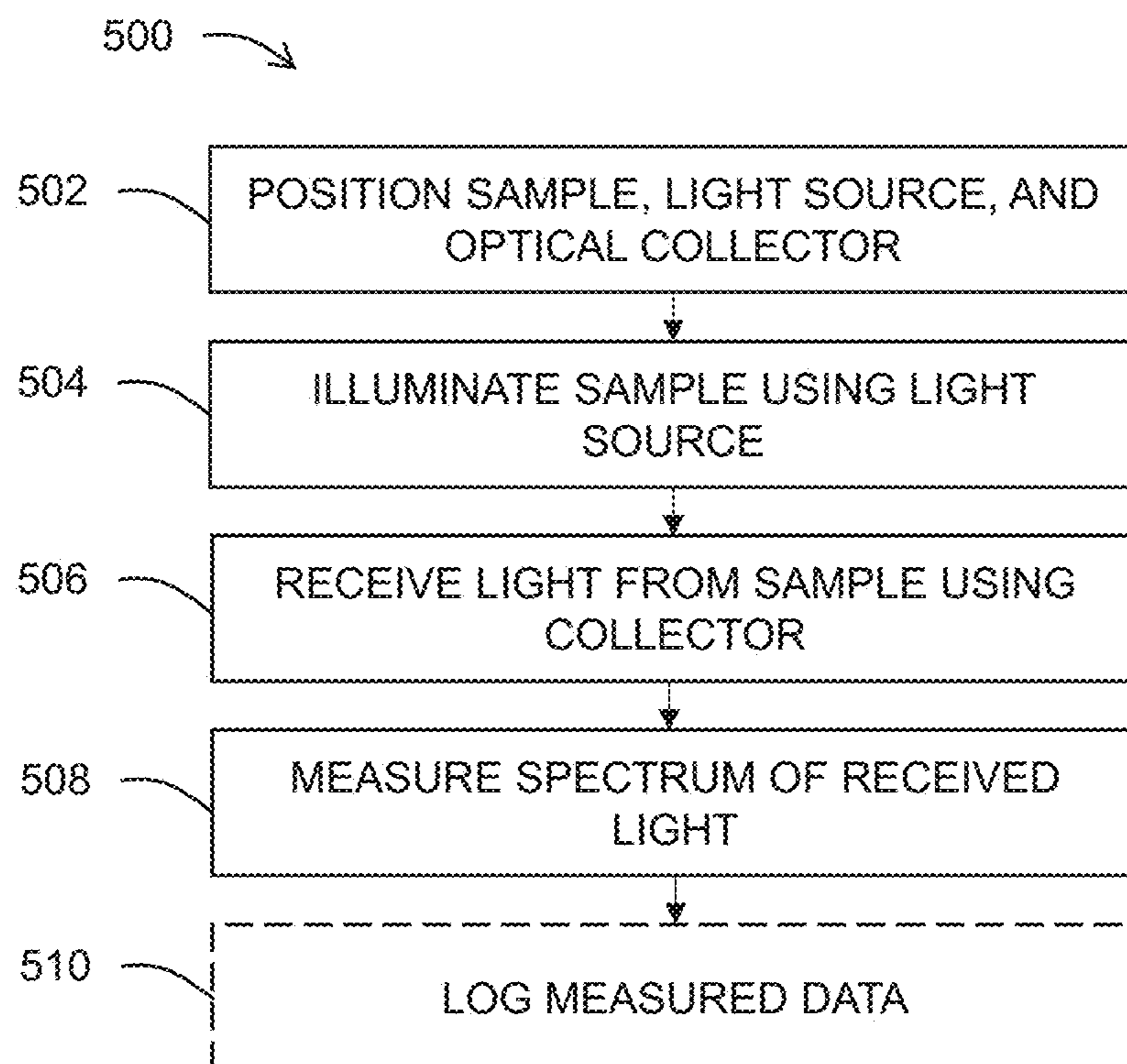

FIG. 17

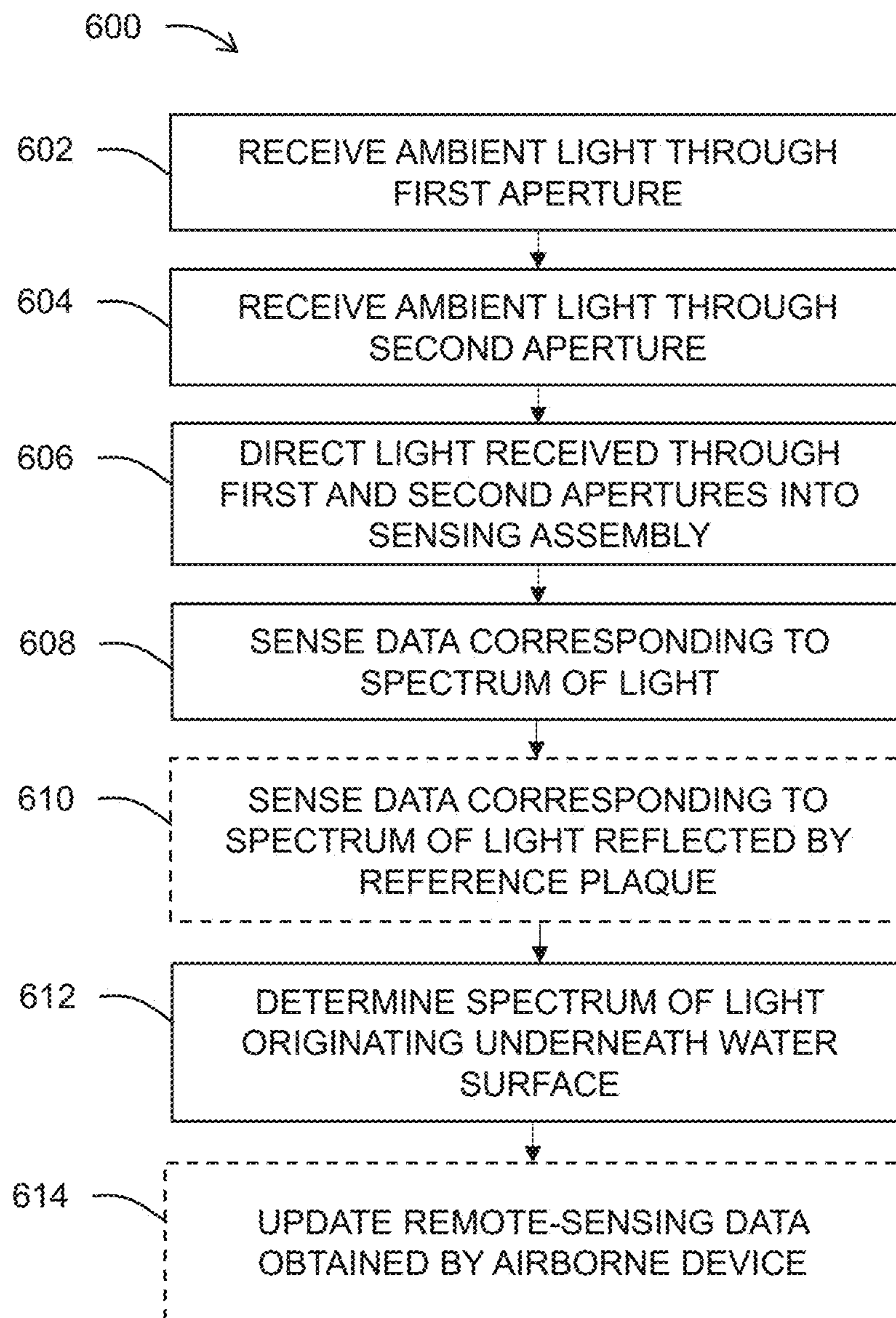

FIG. 18

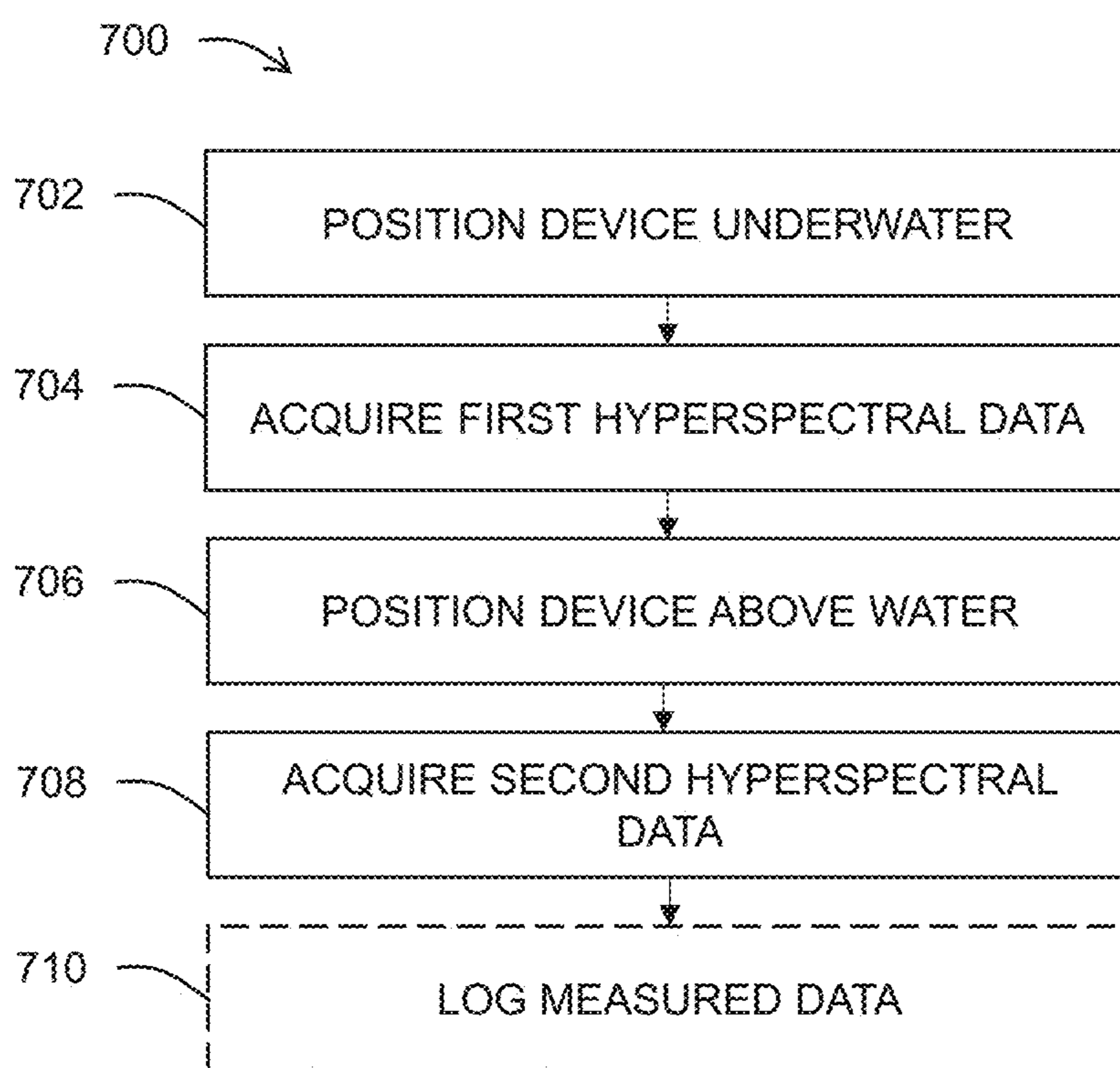

FIG. 19

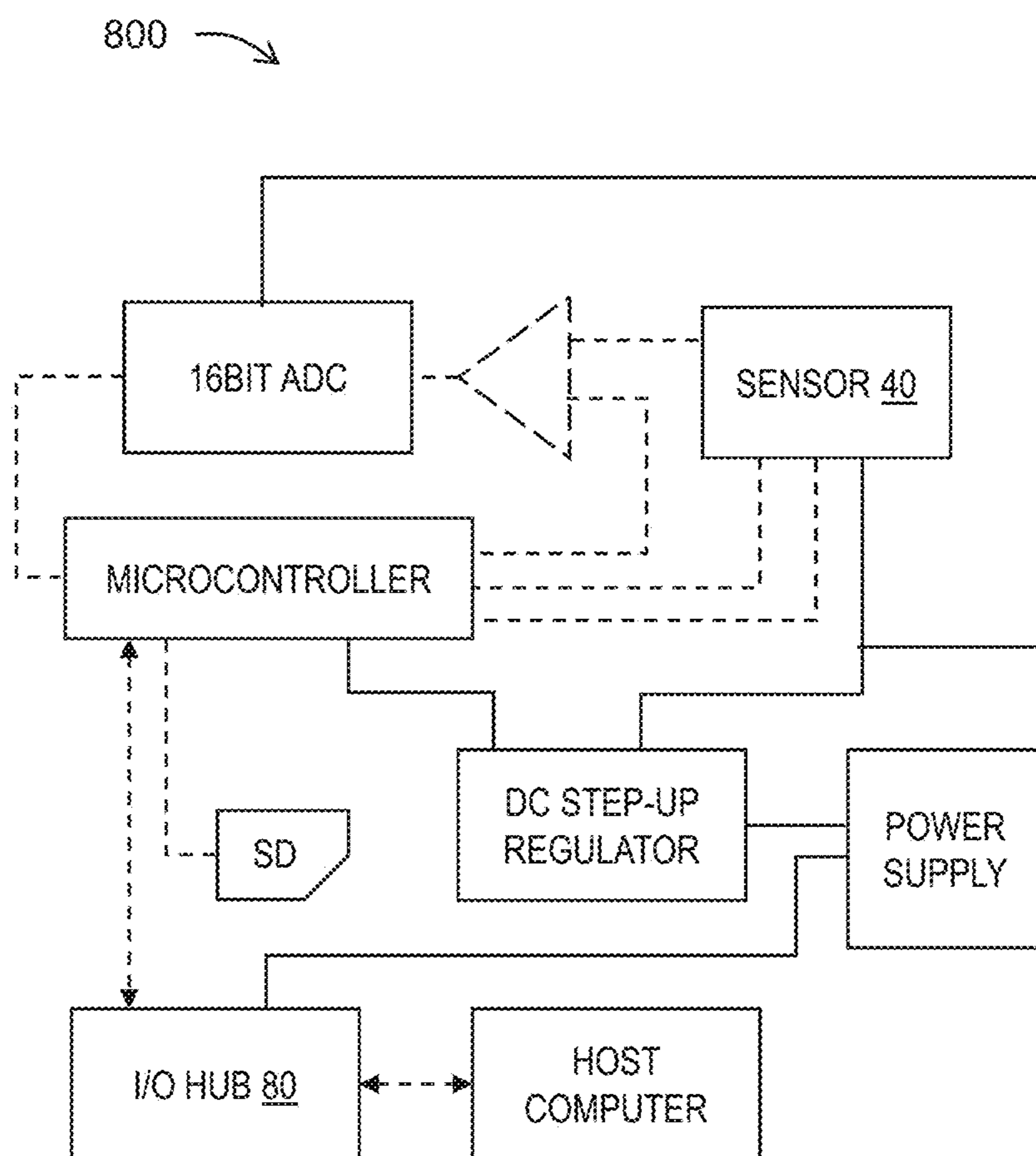

FIG. 20

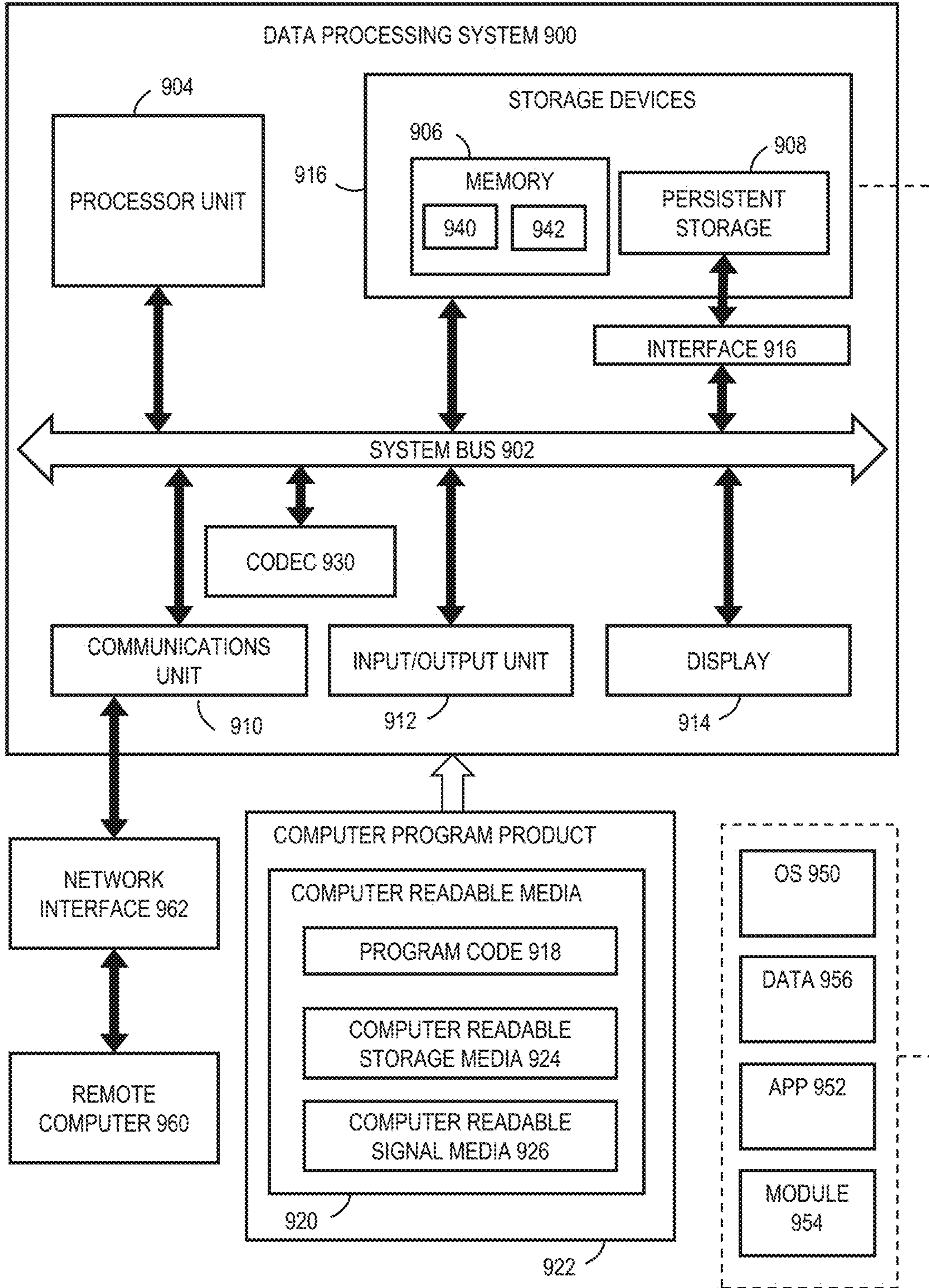

FIG. 21

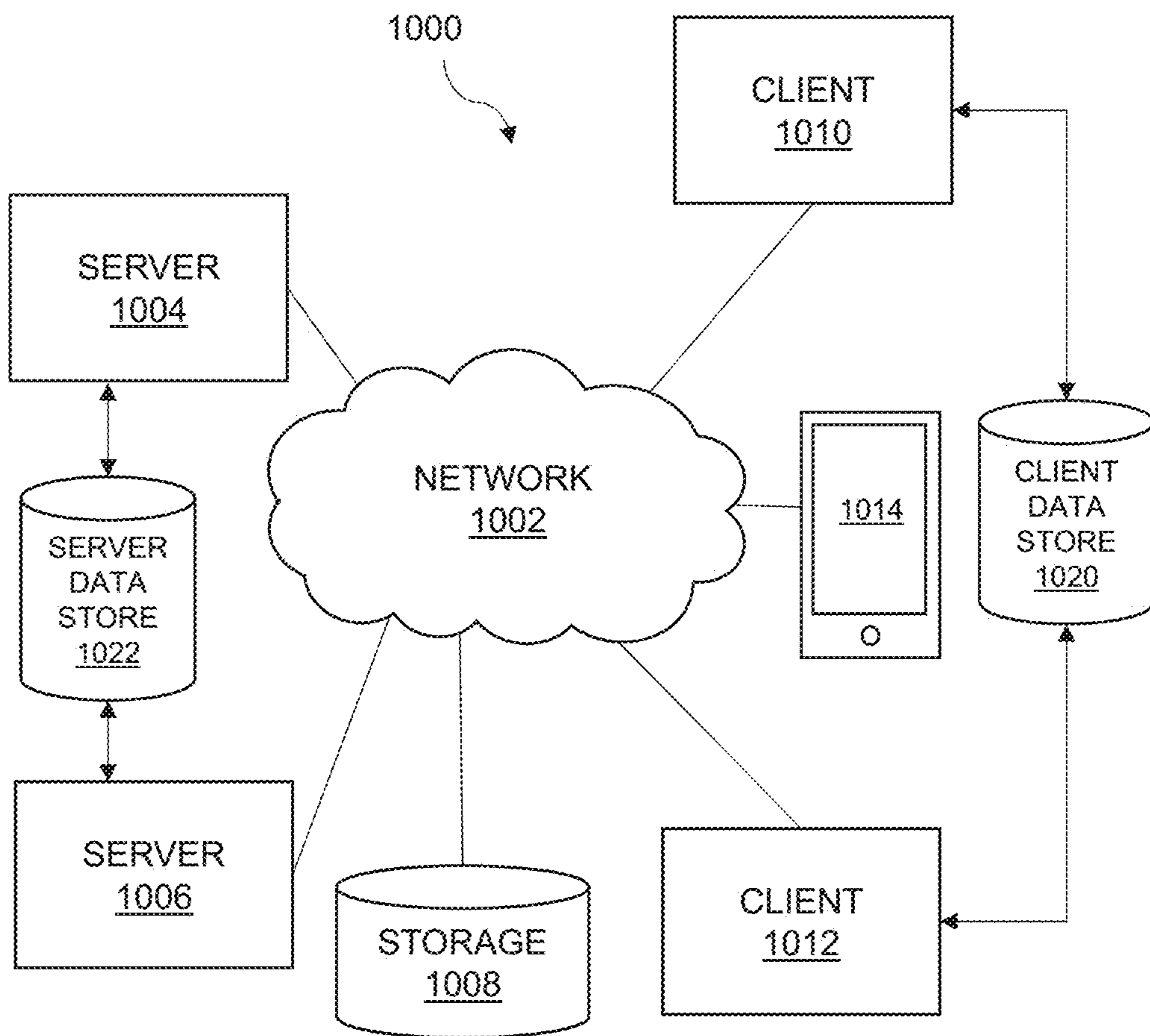

FIG. 22

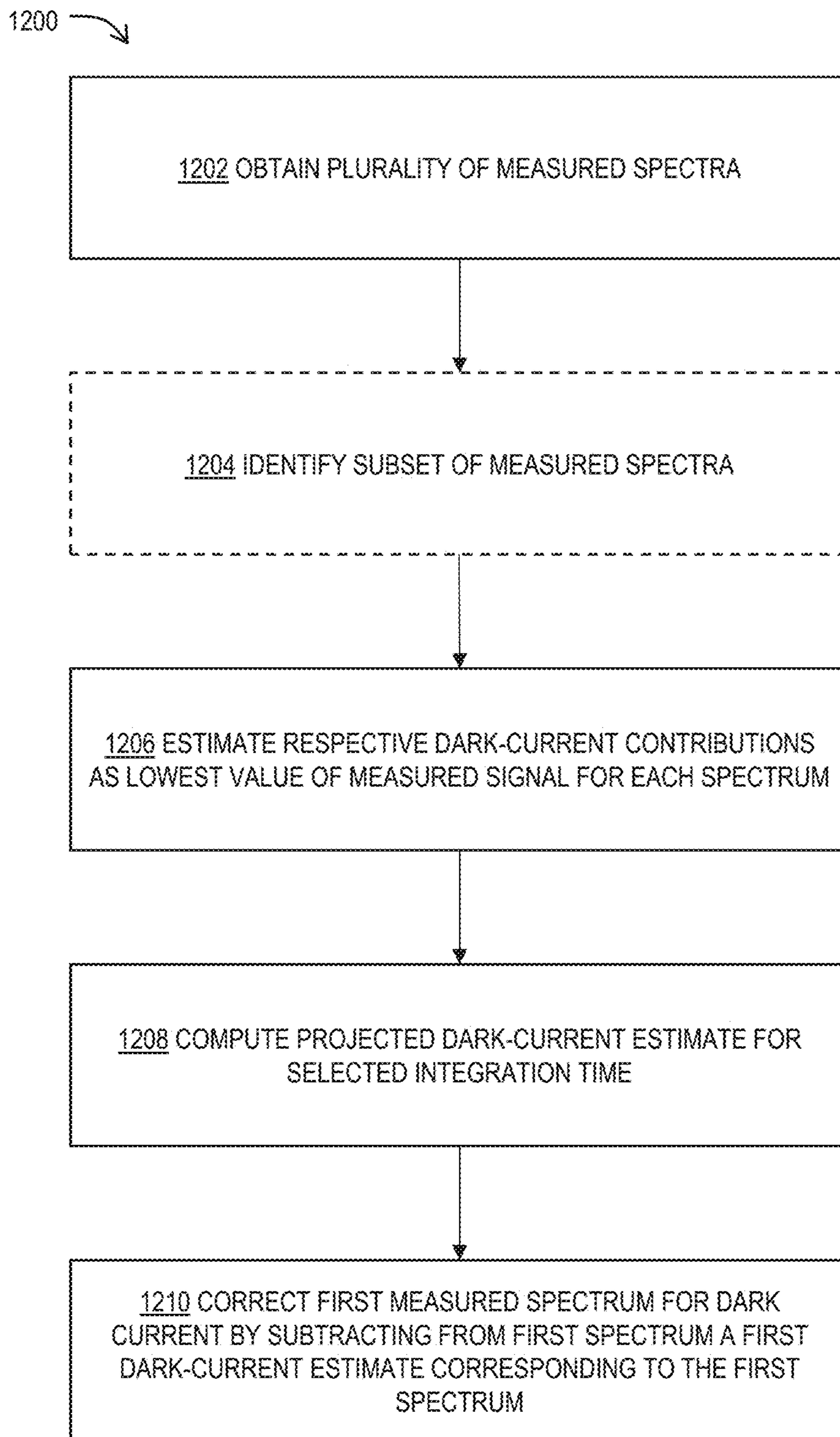

FIG. 23

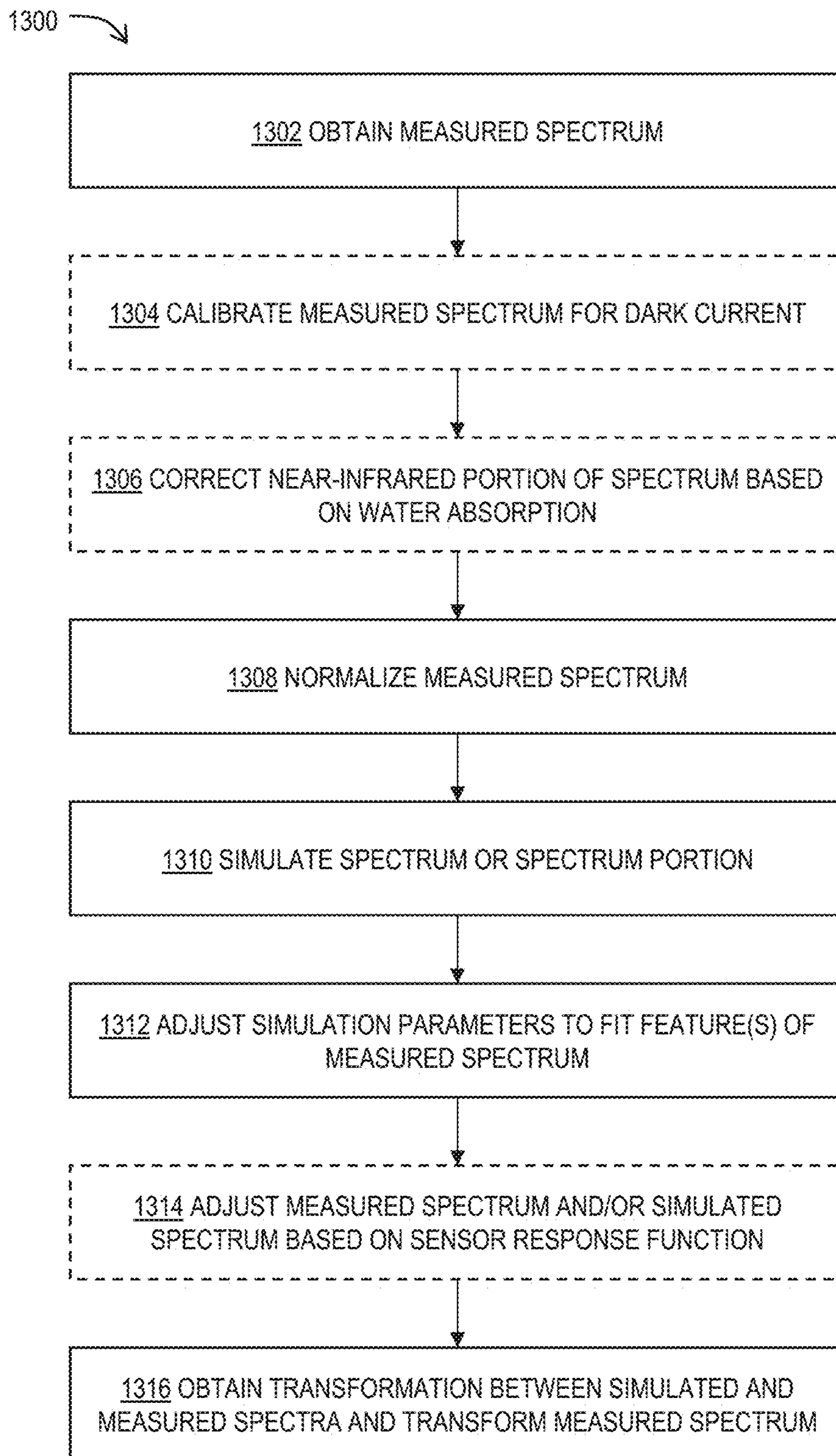

FIG. 24

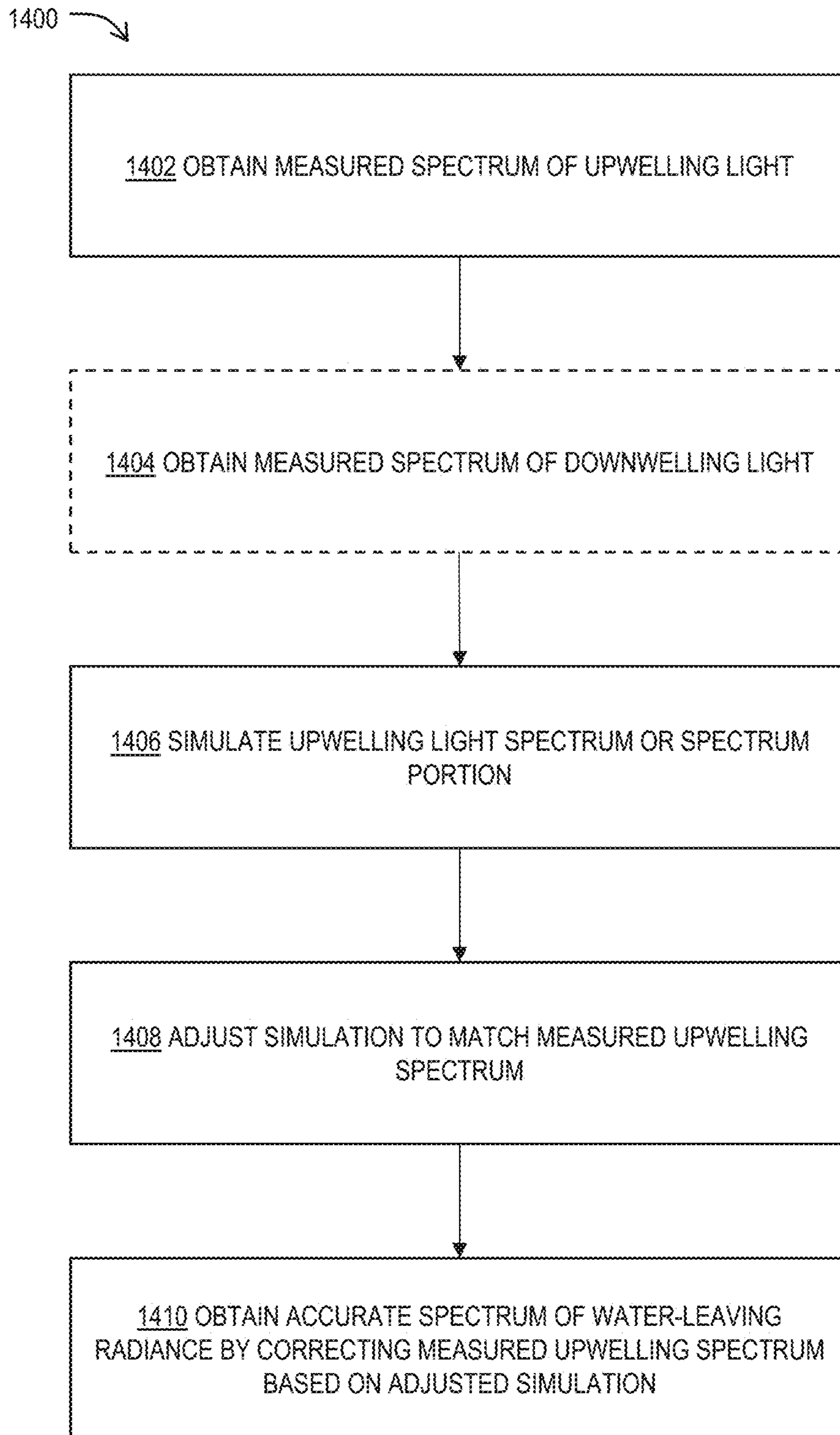

FIG. 25

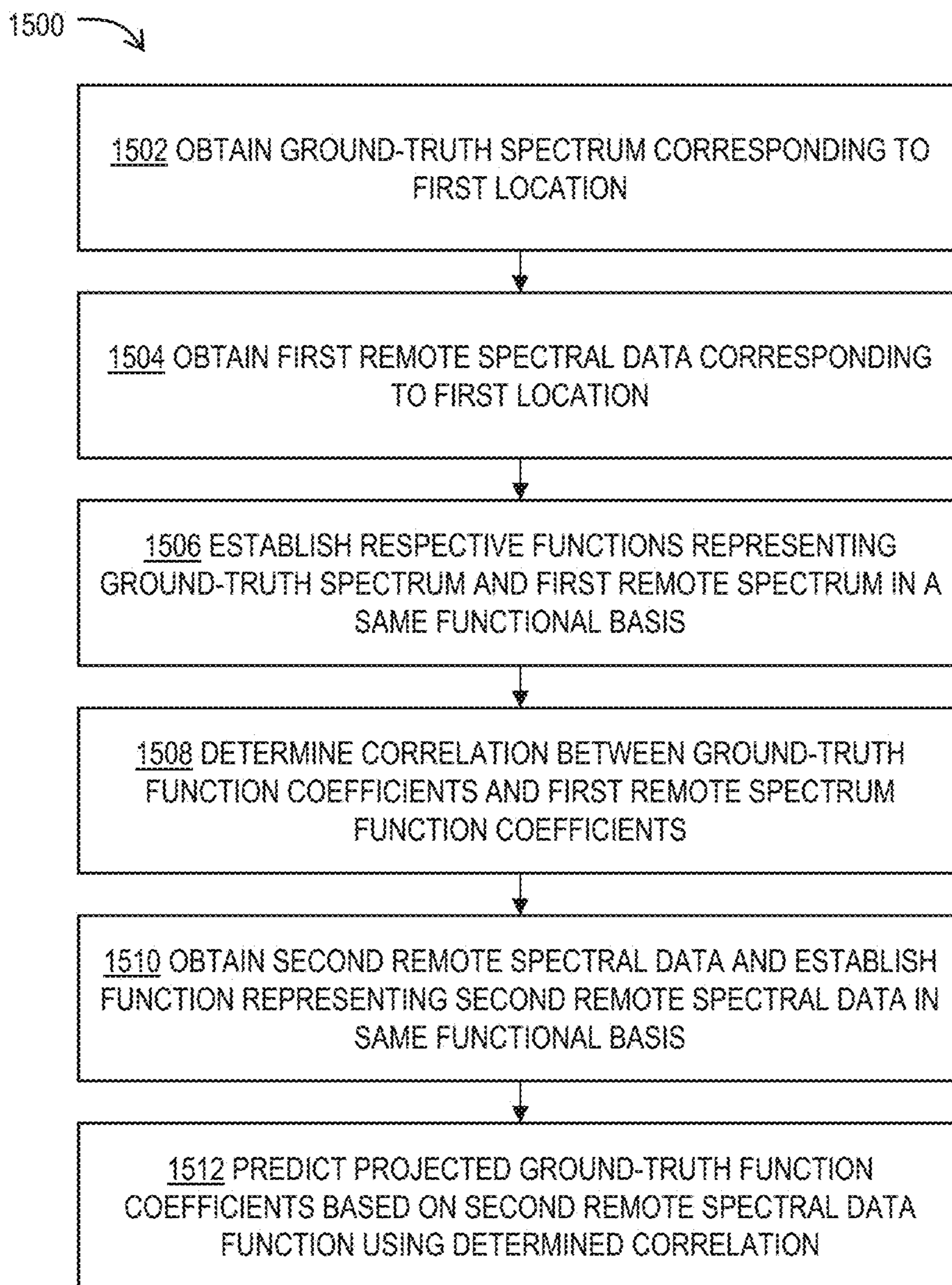

FIG. 26

HYPERSPSPECTRAL SENSING SYSTEM AND PROCESSING METHODS FOR HYPERSPSPECTRAL DATA

CROSS-REFERENCES

[0001] This application is a divisional of U.S. patent application Ser. No. 16/583,042, filed Sep. 25, 2019, which is a continuation in part of U.S. patent application Ser. No. 16/366,635, filed Mar. 27, 2019, which claims the benefit under 35 U.S.C. § 119(e) of U.S. Provisional Patent Application Ser. No. 62/648,779, filed Mar. 27, 2018, the entireties of which are hereby incorporated by reference for all purposes.

FIELD

[0002] This disclosure relates to systems and methods for hyperspectral sensing, including methods of processing, calibrating, and/or analyzing hyperspectral data.

INTRODUCTION

[0003] Optical characteristics of aquatic, terrestrial, and atmospheric environments may be measured to detect the presence and/or abundance of various substances. For example, the wavelength-dependent intensity of light reflected from or absorbed within oceans, lakes, and other bodies of water may be monitored over time to quantify gradual or sudden changes in concentrations of sediment and/or biological matter. Similarly, optical absorption and scattering from land may be monitored to obtain spatial and/or temporal distributions of vegetation, minerals, and/or other substances.

[0004] In many cases, much of the useful information contained in this optical data involves wavelength- or frequency-dependent characteristics of the measured light.

[0005] Systems configured to measure light at a high spectral resolution are therefore desirable. A hyperspectral sensor, which can measure the spectrum of light at each spatial pixel in a region of interest, would provide a large amount of high-resolution data. However, known hyperspectral sensing systems suffer from a number of drawbacks. For example, known systems are typically limited to a single mode of deployment (e.g., above-water deployment only, underwater deployment only, etc.), and are unsuitable for autonomous deployment due to factors such as size, cost, power requirements, and sensitivity to vibration. Accordingly, there is a need for hyperspectral sensing systems configured for field use in water-quality assessment, remote sensing, and/or other similar applications.

SUMMARY

[0006] The present disclosure provides systems, apparatuses, and methods relating to hyperspectral sensing and data.

[0007] In some examples, a method of measuring a radiometrically calibrated spectrum using a spectral sensor deployed at an outdoor location without relocating the spectral sensor comprises measuring a spectrum of light using a spectral sensor deployed at an outdoor location; normalizing the measured spectrum using a selected normalizing factor; computing a simulated spectrum based on a simulation of at least a portion of the atmosphere at the outdoors location, the simulation including one or more adjustable parameters; adjusting at least one of the adjust-

able parameters to produce an adjusted simulated spectrum matching the measured spectrum according to one or more predefined criteria; determining a mathematical transformation capable of transforming the measured spectrum, such that at least a portion of the transformed measured spectrum approximates at least a portion of the adjusted simulated spectrum; and performing the mathematical transformation on the measured spectrum to produce a radiometrically calibrated spectrum.

[0008] Features, functions, and advantages may be achieved independently in various embodiments of the present disclosure, or may be combined in yet other embodiments, further details of which can be seen with reference to the following description and drawings.

BRIEF DESCRIPTION OF THE DRAWINGS

[0009] FIG. 1 is a schematic depiction of an illustrative hyperspectral image in accordance with aspects of the present teachings.

[0010] FIG. 2 is a schematic depiction of an illustrative hyperspectral sensing device in accordance with aspects of the present teachings.

[0011] FIG. 3 is a schematic diagram of an illustrative compact spectrometer in accordance with aspects of the present teachings.

[0012] FIG. 4 is a schematic diagram depicting a hyperspectral sensing system performing a measurement on a discrete sample, in accordance with aspects of the present teachings.

[0013] FIG. 5 is a schematic diagram depicting a hyperspectral sensing system performing a measurement while immersed in a water sample, in accordance with aspects of the present teachings.

[0014] FIG. 6 is an illustrative hyperspectral sensing device configured for performing angularly-resolved hyperspectral measurements, according to aspects of the present teachings.

[0015] FIG. 7 is a schematic diagram of an illustrative optical collector configured to simultaneously collect radiance from two different directions in accordance with aspects of the present teachings.

[0016] FIG. 8 is an isometric view of an illustrative chopper wheel configured to modulate light according to aspects of the present teachings.

[0017] FIG. 9 is a schematic diagram of an illustrative optical collector including a convex reflector, in accordance with aspects of the present teachings.

[0018] FIG. 10 is a schematic diagram of an illustrative optical collector including a movable reflector, in accordance with aspects of the present teachings.

[0019] FIG. 11 is a schematic diagram of an illustrative optical collector including a movable dispersing element, in accordance with aspects of the present teachings.

[0020] FIG. 12 is a schematic diagram of an illustrative optical collector including a beamsplitter, in accordance with aspects of the present teachings.

[0021] FIG. 13 is a schematic diagram of an illustrative optical collector configured to simultaneously collect sky radiance, water radiance, and reference plaque radiance according to aspects of the present disclosure.

[0022] FIG. 14 is a schematic diagram of an illustrative optical collector configured to simultaneously and/or

sequentially measure sky radiance, water radiance, and/or reference plaque radiance according to aspects of the present disclosure.

[0023] FIG. 15 is a schematic diagram of an illustrative network of hyperspectral sensing devices in accordance with aspects of the present teachings.

[0024] FIG. 16 is a flow diagram depicting steps of an illustrative method for simultaneous measurement of sky radiance and water radiance according to the present teachings.

[0025] FIG. 17 is a flow diagram depicting steps of an illustrative method for performing fluorescence, scattering, and/or attenuation measurements on a sample using a hyperspectral sensing system, in accordance with aspects of the present teachings.

[0026] FIG. 18 is a flow diagram depicting steps of an illustrative method for assessing water quality.

[0027] FIG. 19 is a flow diagram depicting steps of an illustrative method for acquiring hyperspectral data above water and underwater.

[0028] FIG. 20 is a schematic diagram depicting an illustrative electronics module of a hyperspectral sensing system, in accordance with aspects of the present teachings.

[0029] FIG. 21 is a schematic diagram of an illustrative data processing system in accordance with aspects of the present teachings.

[0030] FIG. 22 is a schematic diagram of an illustrative distributed data processing system in accordance with aspects of the present teachings.

[0031] FIG. 23 is a flow diagram depicting steps of an illustrative method for obtaining dark-current-corrected spectral data.

[0032] FIG. 24 is a flow diagram depicting steps of an illustrative method for obtaining radiometrically corrected spectral data.

[0033] FIG. 25 is a flow diagram depicting steps of an illustrative method for obtaining data accurately representing water-leaving radiance.

[0034] FIG. 26 is a flow diagram depicting steps of an illustrative method for updating remote spectral data using a correlation between functional-basis representations of another set of remote data and corresponding ground-truth data.

DETAILED DESCRIPTION

[0035] Various aspects and examples of a hyperspectral sensing system, as well as related methods, are described below and illustrated in the associated drawings. Unless otherwise specified, a hyperspectral sensing system in accordance with the present teachings, and/or its various components, may contain at least one of the structures, components, functionalities, and/or variations described, illustrated, and/or incorporated herein. Furthermore, unless specifically excluded, the process steps, structures, components, functionalities, and/or variations described, illustrated, and/or incorporated herein in connection with the present teachings may be included in other similar devices and methods, including being interchangeable between disclosed embodiments. The following description of various examples is merely illustrative in nature and is in no way intended to limit the disclosure, its application, or uses. Additionally, the advantages provided by the examples and embodiments described below are illustrative in nature and

not all examples and embodiments provide the same advantages or the same degree of advantages.

[0036] This Detailed Description includes the following sections, which follow immediately below: (1) Definitions; (2) Overview; (3) Examples, Components, and Alternatives; (4) Advantages, Features, and Benefits; and (5) Conclusion. The Examples, Components, and Alternatives section is further divided into subsections A through P, each of which is labeled accordingly.

Definitions

[0037] The following definitions apply herein, unless otherwise indicated.

[0038] “Substantially” means to be more-or-less conforming to the particular dimension, range, shape, concept, or other aspect modified by the term, such that a feature or component need not conform exactly. For example, a “substantially cylindrical” object means that the object resembles a cylinder, but may have one or more deviations from a true cylinder.

[0039] “Comprising,” “including,” and “having” (and conjugations thereof) are used interchangeably to mean including but not necessarily limited to, and are open-ended terms not intended to exclude additional, unrecited elements or method steps.

[0040] Terms such as “first,” “second,” and “third” are used to distinguish or identify various members of a group, or the like, and are not intended to show serial or numerical limitation.

[0041] “AKA” means “also known as,” and may be used to indicate an alternative or corresponding term for a given element or elements.

[0042] “Coupled” means connected, either permanently or releasably, whether directly or indirectly through intervening components.

[0043] “Processing logic” means any suitable device(s) or hardware configured to process data by performing one or more logical and/or arithmetic operations (e.g., executing coded instructions). For example, processing logic may include one or more processors (e.g., central processing units (CPUs) and/or graphics processing units (GPUs)), microprocessors, clusters of processing cores, FPGAs (field-programmable gate arrays), artificial intelligence (AI) accelerators, digital signal processors (DSPs), and/or any other suitable combination of logic hardware.

Overview

[0044] In general, a hyperspectral sensing system in accordance with aspects of the present teachings is configured to obtain hyperspectral data while deployed in the field (e.g., adjacent a body of water, underwater, on an aerial vehicle, and/or the like). Typically, the hyperspectral sensing system includes a sensor configured to measure a spectrum of light with a high spectral resolution, along with one or more optical assemblies configured to direct light to the sensor. For example, the system may comprise one or more compact spectrometers (AKA miniature spectrometers) and suitable optics.

[0045] Hyperspectral data generally comprises an image composed of one or more spatial pixels, with high-resolution spectral information (e.g., wavelength-dependent or frequency-dependent information) associated with each pixel. The spectral information may include a measured light level

(e.g., brightness, energy, power, and/or intensity of light) in each of a plurality of narrow, adjacent spectral bands. Hyperspectral data may be represented by a hyperspectral image, which may be thought of as a three-dimensional image or hyperspectral cube having two spatial dimensions and one spectral dimension. FIG. 1 depicts an illustrative hyperspectral image 20 comprising a plurality of two-dimensional images 22 of a coastal region, wherein each two-dimensional image corresponds to a detected level of light within a respective spectral band. In other words, each pixel 25 of one of the two-dimensional images 22 is associated with a level of light detected within the spectral band associated with that two-dimensional image.

[0046] Accordingly, as shown schematically in FIG. 1, a set 27 of pixels 25 corresponding to a same location in each of the two-dimensional images comprises a spectrum of detected light levels for the corresponding location across all spectral bands in hyperspectral image 20. The spectrum associated with set 27 may be illustrated as a plot 29 depicting measured light level (e.g., percentage of light reflected) as a function of wavelength for the location associated with the selected pixel 25. Hyperspectral image 20 comprises such a spectrum for each spatial pixel in the image.

[0047] For simplicity, only a few two-dimensional images 22 are depicted in FIG. 1, and therefore the depicted hyperspectral image 20 comprises only a few spectral bands. Typically, however, hyperspectral images include light levels associated with at least tens or hundreds of adjacent and/or narrowly spaced spectral bands, such that the spectrum associated with a given pixel across the plurality of two-dimensional images (e.g., a spectrum like that depicted in plot 29) is, to good approximation, continuous.

[0048] A hyperspectral sensing system may be referred to as a hyperspectral imaging system and/or a hyperspectral imager. As discussed below, the hyperspectral sensing system of the present disclosure is configured to log (e.g., record) hyperspectral data and therefore may also be referred to as a hyperspectral logger, hyperspectral logging system, hyperspectral logging radiometer, and/or optical data logger.

[0049] A hyperspectral sensing system in accordance with aspects of the present teachings is typically well suited for use in water-quality assessments, remote sensing, underwater deployment, and/or other field settings. For example, the system may comprise one or more devices that are small in size, lightweight, suitable for use in or adjacent water, relatively insensitive to vibration, and/or configured to acquire data without careful alignment and/or frequent calibration. In some examples, a hyperspectral sensing system comprises a network of hyperspectral sensing devices distributed in a suitable location and configured to store and/or transmit sensed data.

[0050] A hyperspectral sensing system in accordance with aspects of the present teachings may be used to acquire hyperspectral data in a variety of deployment modalities. For example, the system typically has a low physical volume and a low weight and is therefore suitable for aerial deployment, e.g., on an airplane, unmanned aerial vehicle, weather balloon, and/or the like. In some examples, the system may also be deployed underwater, e.g., on a watercraft, buoy, unmanned underwater vehicle, manually operated by a diver, and so on. Additionally, or alternatively, the system may be deployed on the ground, adjacent a body of water,

and/or in any other suitable location. In some examples, the system is configured to simultaneously measure light incident from multiple directions, e.g., from the sky and from a body of water.

[0051] In some examples, the system is used to acquire data from a discrete sample (e.g., a sample of water and/or another fluid) collected by a profiling system (e.g., a rosette comprising an array of Niskin bottles, Scotty bottles, and/or the like, and optionally including sensors such as CTD sensors). In some examples, a sample of fluid is collected by a flow-through system configured to pump fluid into a sample chamber, and the system acquires data from the sample within the sample chamber. These capabilities are discussed further below.

Examples, Components, and Alternatives

[0052] The following sections describe selected aspects of exemplary hyperspectral sensing systems as well as related systems and/or methods. The examples in these sections are intended for illustration and should not be interpreted as limiting the scope of the present disclosure. Each section may include one or more distinct embodiments or examples, and/or contextual or related information, function, and/or structure.

A. Illustrative Hyperspectral Sensing Device

[0053] With reference to FIG. 2, this section describes an illustrative hyperspectral sensing device 30. Device 30 is an example of the hyperspectral sensing systems described above.

[0054] As shown in FIG. 2, which is a schematic depiction of device 30, the device includes an optical collector 35 configured to collect light from a sample spatial region. The sample region may include a landmass, a body of water, a portion of the atmosphere, and/or any other suitable area or object of interest.

[0055] Collector 35 is further configured to transfer the collected light from the sample region to a sensor 40. Transferring the light to sensor 40 typically includes steering the light toward the sensor and may further include minimizing optical distortions, aberrations, and/or stray light. In some examples, transferring the light to sensor 40 includes imaging the sample region onto the sensor (e.g., onto a slit of the sensor, onto a sensing element of the sensor, and/or the like).

[0056] Light collected by collector 35 includes light emitted by, reflected by, and/or transmitted through objects within the sample region viewable by collector 35. The viewable region may be characterized by, e.g., an angular field of view (AFOV) and/or a horizontal or vertical field of view (FOV) of collector 35, e.g., at a desired working distance from the collector (e.g., at the object plane). The spectrum of the collected light (e.g., the intensity, brightness, radiance, and/or other level of the collected light as a function of wavelength) may be used to characterize objects within the sample region. For example, if the sample region includes a portion of a landmass, the collected light may primarily include light reflected from the landmass portion, and the spectrum of the reflected light may be used to infer mineral content of the landmass portion. The objects and/or portions of objects within the viewable sample region may be referred to as samples, and collecting light from the samples (e.g., acquiring a single spectrum and/or sequen-

tially acquiring a plurality of spectra of the same viewable region) may be referred to as sampling.

[0057] Collector **35** may comprise any assembly of optical components suitable for collecting light from the sample region and transferring the collected light to sensor **40**. For example, collector **35** may comprise an aperture, an entrance slit, an optical tube, and/or a fiber optic guide. An optical fiber configured to guide input light collected by an entrance aperture and/or fore-optic to the detector plane of sensor **40** may be useful when objects or other physical obscurations are disposed between the sample and the sensor, or when it is desirable to physically separate the sensor from the sample. For example, samples may be difficult to physically access due to space available or fragile environments such as in proximity to under-water vegetation, rock formations, or coral structures. In other cases, a desirable or optimal location of the optical sampling port on a deployment vessel, or reducing the instrument and vessel self-shading of the sample area, may require separating the instrument from the sampling entrance port.

[0058] Additionally, or alternatively, collector **35** may include a compound mirror and/or lens system with fore-optics; relay optics, diffusers, dispersive optical elements, and/or other homogenizing elements; polarizing elements; and/or adaptive telescope and/or microscope objectives with wavefront correction. In some examples, collector **35** includes optics configured to increase the uniformity of a spatial distribution (e.g., an angular distribution) of collected light. For example, collector **35** may include a diffusing collector with a cosine response, AKA a cosine corrector, configured to acquire a 180-degree FOV irradiance, and to accurately weight the angular distribution of an incoming incoherent light-field. A cosine corrector may be particularly useful for, e.g., measurements of sky irradiance or under-water downwelling or upwelling radiances. Light from an inhomogeneous source may also be generally made more uniform by a ground-glass diffuser, a fly's-eye homogenizer, or diffractive optical elements (DOE) within collector **35**.

[0059] In some examples, one or more linear polarizing optical elements and/or one or more circular polarizing optical elements are included in collector **35** to select and/or measure the polarization of the incoming light field as a function of wavelength and of angle of polarization. The angular orientation(s) of the polarizer(s) may be actuated manually and/or mechanically by automated and/or motorized control. The polarizing element or elements may be moved in or out of the optical path manually and/or mechanically by automated and/or motorized control. The polarizer(s) may be used, for example, to perform a hyperspectral polarization measurement to identify specific substances (e.g., substances having light-polarizing characteristics). A hyperspectral polarization measurement may be performed, for example, using light reflected from the surface of a body of water. Such light is typically polarized by the refraction and reflection at the air-water interface, and may be additionally polarized by the absorption from water molecules or other suspended matter in the surface layer. A circular polarizer may be used, for example, to reduce or amplify the light reflected from the surface of a body of water.

[0060] In some examples, collector **35** is configured to be dynamically actuated to vary the field of view, depth of focus, and/or other parameters. For example, collector **35** may include an entrance slit of adjustable size (e.g., an

adjustable aperture, such as an iris). Optical diffusers, such as ground glass or quartz diffusers, may be used to mix the angular distribution of light across the sampled region. Additionally, or alternatively, positions of optical collector elements such as lenses may be adjustable. For example, optical collector elements may be mounted on translation stages such that distances between sensor **40** and optical collector elements is variable. In examples including adjustable collector elements, the size (e.g., spatial extent) of the pixels sampled by device **30** may be variable while the distance between sensor **40** and the sampled object is fixed. The spatial distribution sampled by device **30** may thus be varied without changing the position of sensor **40**. Additionally, adjusting the position of the focal plane of a collector may help to sample the imaging contribution of a desired best-focus plane. Collector **35** may include steering optics configured to selectively change the lateral location of the image field and thereby scan a larger sampling area than possible with a fixed sampling location.

[0061] In some examples, optical elements within collector **35** may be individually adjustable and/or removable and replaceable. For example, optical collector elements may be mounted by bolts and/or screws to an optical breadboard having threaded bores. Additionally, or alternatively, collector **35** may be configured to be detachable from device **30** (e.g., from a housing of the device) and replaced with another collector. For example, a collector **35** configured to sample objects far away from device **30** may be replaced with a collector configured to sample objects very close to the device. The ability to adjust and/or replace collector **35** helps device **30** to collect data in a variety of settings and/or modes of deployment.

[0062] As described above, collector **35** is configured to transfer sampled light into sensor **40** (e.g., onto an entrance aperture of sensor **40**). Sensor **40** may comprise any suitable device configured to receive light and to measure the level (e.g., an energy, power, and/or intensity) of the received light in a plurality of narrow spectral bands. Typically, sensor **40** includes a dispersive optical element configured to spatially separate spectral components of the received light, and one or more detectors configured to measure light intensity at a plurality of spatial points. The measured intensity at each spatial point corresponds to the intensity of light in a certain spectral band. The mapping between spatial points and spectral bands can be calculated based on, e.g., the dispersive properties of the dispersive element, the relative positions between the dispersive element and the spatial points, and so on. Sensor **40** is typically a compact optoelectronic device, such as a spectrometer or mini-spectrometer (see FIG. 3 and associated description in Section B). In some examples, however, sensor **40** may comprise another type of device, such as a spectrophotometer, a CCD array, a CMOS array, and/or the like.

[0063] Collector **35** may include optics configured to at least partially correct imperfections in the radiometric (spectral) or angular response of sensor **40** arising from wavefront aberrations introduced by various components of the sensor (e.g., an entrance aperture, a dispersive element such as grating or prism, coatings, and/or sensor imperfections). Sensor **40** may be disposed in any suitable position relative to collector **35** to receive the light from the collector. In some examples, sensor **40** may be positioned adjacent to and/or coupled to collector **35**.

[0064] As shown in dashed lines in FIG. 2, device 30 optionally includes a second sensor 40, and may include a second collector 35 configured to collect light and transfer the collected light to the second sensor. In examples wherein device 30 includes two or more sensors, collectors corresponding to the two or more sensors may be configured to collect light incident from different directions. For example, the first collector may transfer light incident from a first direction onto the first sensor, and the second collector may transfer light incident from a second direction onto the second sensor. In some examples, a single collector 35 is configured to direct light from two different directions onto two different sensors. In examples wherein device 30 includes two or more collectors, the two or more collectors may have different optical properties (e.g., different fields of view, focal lengths, and/or the like), or may be substantially identical. If two or more sensors are included, they may have different properties (e.g., sensitivity, dynamic range, wavelength range, etc.) or may be substantially identical. Use of two or more sensors may enable device 30 to acquire data from two or more samples simultaneously. (However, see also Section D below, describing illustrative collectors configured to enable simultaneous measurements with a single sensor.)

[0065] In addition to sensor 40, device 30 optionally includes one or more auxiliary sensors 50 such as GPS receivers, thermometers, pressure sensors (e.g., for depth and/or altimetry), humidity sensors, CTD sensors (AKA Sonde sensors), dissolved oxygen sensors, compasses, inertial measurement units, real-time clock (RTC) oscillators, photodiodes, pH sensors, dissolved Nitrogen (nitrates) sensors, dissolved organic carbon sensors, dissolved inorganic carbon sensors, and/or any other suitable sensors. The fusion of multiple sensor inputs may be very useful for precision optical measurements, because the output of one sensor (e.g., sensor 40 or one of auxiliary sensors 50) can be strongly coupled to a physical property measurable by a separate sensor. For example, the ability of sensor 40 to correctly measure the wavelength of light may depend linearly or nonlinearly on the temperature of the sensor and therefore on the temperature of the environment in which the sensor is used. Based on the relationship between measured wavelength and sensed temperature, a correction to the wavelength reading can be performed based on data measured by a temperature sensor in proximity to sensor 40. This improves the accuracy and stability of the obtained hyperspectral data. In some examples, corrections based on temperature (or other data measured by auxiliary sensor 50) are performed on board device 30 (e.g., by an electronics module) at the analog-circuit level and/or digitally (following the analog-to-digital conversion). Additionally, or alternatively, the correction may be implemented on an external computer after the data is transferred off-board the hyperspectral data-logging device.

[0066] Additionally, or alternatively, device 30 may include a light source 60. Light source 60 may be configured to illuminate at least a portion of the sampling region with a light having a predetermined intensity, propagation direction, polarization, and/or range of wavelengths. Light source 60 may enable measurements involving fluorescence, absorption, scattering, and/or the like.

[0067] Device 30 further includes an electronics module 70. Electronics module 70 includes a memory store 75 coupled to sensor 40 and configured to store data obtained

by the sensor. Optionally, memory store 75 may be configured to store data from sensor 40 in association with data from auxiliary sensors 50 corresponding to, e.g., a timestamp corresponding to the time at which the data was collected, GPS coordinates, ambient temperature, settings of the sensor, and/or the like. Memory store 75 may be non-volatile (e.g., configured to continue storing data when disconnected from a power source) and/or volatile (e.g., configured to discontinue storing data when disconnected from a power source). In examples including a volatile memory, using device 30 may include transferring data from the volatile memory to an external storage device prior to disconnecting the memory from a power source.

[0068] Electronics module 70 may include processing logic 78 configured to, e.g., trigger sensor 40 and/or auxiliary sensors 50 to start and/or stop collecting data, actuate adjustable elements of collector 35, write data from sensor 40 and/or auxiliary sensors 50 to memory store 75, and/or communicate with an input/output hub of device 30. For example, signals from auxiliary sensors 50 may be read by electronics module 70, which may selectively trigger sensor 40 to perform measurements based on the auxiliary sensor readings (e.g., when the auxiliary sensor readings satisfy one or more criteria). For example, electronics module 70 may trigger device 30 to perform measurements in response to signals from a pressure sensor indicating that the device (or portion thereof, such as collector 35) is disposed at a predetermined depth underwater. As another example, electronics module 70 may trigger sensor 40 to perform measurements in response to signals from a tilt sensor (e.g., an IMU) indicating a predetermined orientation of collector 35 or other components of the device. The predetermined orientation may, for example, enable measurements of sky radiance at a desired angle relative to the horizon and/or to the sun. As yet another example, signals from a clock or a GPS receiver may be used to trigger measurements at desired times and/or locations.

[0069] In some examples, two or more criteria are associated with the information sensed by a single auxiliary sensor. For example, electronics module 70 may perform an action (e.g., trigger a reading, vary a sampling rate and/or integration time of sensor 40, etc.) based both on the actual value of data acquired by the auxiliary sensor and on the rate at which the data changes with time. For example, if information sensed by a depth sensor indicates that the depth of device 30 below water is at least a predetermined amount and is also changing rapidly, electronics module 70 may increase the rate at which the system acquires data.

[0070] In some examples, auxiliary sensors 50 include at least one photodiode (or other suitable device), and electronics module 70 is configured to turn off power to sensor 40, at least some auxiliary sensors 50, and/or other components of device 30 in response to data from the photodiode indicating that light levels are below a predetermined threshold. The predetermined threshold may correspond to light levels associated with a time of day (e.g., night-time), with a specified depth underwater, and/or with a specified tilt angle. Electronics module 70 may restore power in response to information from the photodiode indicating that light levels are above the predetermined threshold. Shutting down power based on information sensed by the photodiode may reduce total power consumption of device 30 during deployment, and may thereby extend the length of deployment of an autonomous and/or manually operated device.

[0071] Additionally, or alternatively, electronics module 70 may power down components of device 30 in response to information from a real-time clock. For example, electronics module 70 may shut down sensor 40 and auxiliary sensors 50 when the real-time clock indicates that it is night time, and may turn on power to sensor 40 and auxiliary sensors 50 when the real-time clock indicates that it is morning.

[0072] In some examples, triggering may be additionally or alternatively based on signals from sensor 40. For example, electronics module 70 may vary the sampling rate or integration time of sensor 40 based on the intensity of light recently measured by the sensor (e.g., across the entire spectrum measurable by sensor 40 or across any suitable portion(s) of the measurable spectrum). In this way, device 30 may autonomously adapt to, e.g., changing amounts of incident light. For example, electronics module 70 may change settings of sensor 40 to settings suitable for low amounts of light when the measured intensity is low, and, in response to an increase in measured intensity, change the settings to be suitable for larger amounts of light.

[0073] Device 30 further includes an input/output hub 80 allowing for communication of data between device 30 and other devices (e.g., computers, mobile devices, servers, and/or the like). For example, input/output hub 80 may include one or more interface ports such as serial ports, parallel ports, and/or universal serial bus (USB) ports. The interface ports may include dedicated input ports, dedicated output ports, and/or ports capable of both input and output. For example, a USB port may be used to provide input to device 30 and to output information from the sensing system to an external computer or other external device. In some examples, input/output hub 80 includes a wireless communication circuit, which may transmit and/or receive information using, e.g., a WiFi wireless technology protocol, a Bluetooth® wireless technology protocol, an Iridium® wireless communications system, and/or the like. Input/output hub 80 may be used to retrieve data from device 30 (e.g., from memory store 75, from a buffer within electronics module 70, and/or directly from sensor 40). For example, data may be transferred via input/output hub 80 to an external computer for storage and/or analysis. Input/output hub 80 may additionally or alternatively be used to input instructions related to the operation of device 30. For example, a user may use an external computer and/or mobile device coupled to input/output hub 80 to select a parameter of sensor 40 (e.g., integration time, sampling rate, and/or the like). The selected parameter is communicated via input/output hub 80 to sensor 40 and/or to electronics module 70.

[0074] In some examples, device 30 includes one or more data processing systems (e.g., computers), such as a single-board Linux computer and/or other suitable system. The data processing system may communicate with, and/or be part of, electronics module 70 and/or input/output hub 80. The data processing system may facilitate transfer of data between device 30 and an external system. In some examples, the data processing system remains in a low-power standby mode until woken by electronics module 70 (e.g., by one or more microcontrollers of the electronics module) for data transfer and/or any other suitable purpose. In this manner, power is conserved by keeping the computer in standby mode during much of the time the device is deployed.

[0075] Device 30 further includes a power source 90. Power source 90 may include any suitable battery or batteries, rechargeable or otherwise, such as a lead-acid battery,

a lithium-ion battery, a lithium-polymer battery, a nickel-cadmium battery, and/or the like. The battery may be a secondary cell in communication with a battery-charging circuit configured to receive power from an external source and convert the received power into an electrical current usable to charge the battery (e.g., a DC current). The charging circuit may be configured to charge the battery by inductive charging, infrared power transmission, radio-frequency power transmission, and/or by drawing power from another device via a USB interface port. Power source 90 provides power to components of device 30 having need of a power supply (e.g., needing a voltage or current source). For example, power source 90 may supply electrical power to sensor 40, any motorized components of collector 35, input/output hub 80, electronics module 70, light source 60, and/or auxiliary sensors 50. In some examples, power source 90 comprises a photovoltaic device (e.g., one or more photovoltaic panels, and/or any other suitable solar power device).

[0076] Typically, device 30 includes an enclosure or housing 95 configured to at least partially contain the components described above. Housing 95 is generally designed to be suitable for deployment in rough environments (e.g., outdoors, on ships and/or buoys, on aerial vehicles, etc.). For example, the housing may be water-resistant or water-tight, and may be configured to resist corrosion. In some examples, housing 95 is configured to protect its contents when deployed underwater.

B. Illustrative Compact Spectrometer

[0077] With reference to FIG. 3, this section describes an illustrative compact spectrometer 100. Compact spectrometer 100 is an example of sensor 40 suitable for use in a hyperspectral sensing system in accordance with aspects of the present teachings, as described above. Accordingly, compact spectrometer 100 is configured to measure an intensity of impinging light in each of a plurality of adjacent narrow spectral bands. Compact spectrometer 100 may be referred to as a microspectrometer, and/or an ultra-compact spectrometer.

[0078] FIG. 3 is a schematic depiction of compact spectrometer 100. As shown in FIG. 3, compact spectrometer 100 includes an input slit 110 through which incident light enters. The incident light is typically light emitted by, reflected by, scattered from, and/or transmitted through sample objects within the field of view of collector 35. Collector 35 directs the incident light through input slit 110, which may include imaging the sample objects onto input slit 110.

[0079] The incident light is transmitted through a hollow space in compact spectrometer 100 and impinges on grating 115. Grating 115 is a diffraction grating comprising an array of fine, parallel grooves on a curved reflective substrate. In the example depicted in FIG. 3, grating 115 comprises a reflective concave blazed grating, having grooves shaped to form right triangles, but any suitable type of grating may be used (e.g., a holographic grating, a ruled grating, an echelle grating, and/or any other suitable grating). In some examples, a different dispersive element (e.g., a transmissive grating and/or a prism) is used instead of grating 115.

[0080] In general, light impinging on grating 115 is reflected from the grating in a propagation direction determined at least partially by the wavelength of the light. In other words, grating 115 disperses or separates the incident

light into a plurality of chromatic components (e.g., spectral component or colors), and the chromatic components are reflected from the grating in a wavelength-dependent manner.

[0081] The curvature of grating **115**, which is concave toward input slit **110**, focuses the reflected incident light toward an image sensor **120**. Image sensor **120** is configured to measure an amount (e.g., an intensity) of the dispersed and reflected incident light from grating **115** at each of a plurality of spatial positions and/or pixels of the image sensor. Because grating **115** reflects light in a wavelength-dependent direction, the location on image sensor **120** at which light was measured corresponds to the wavelength of the light. Image sensor **120** may comprise a linear CMOS array (e.g., a CMOS device comprising a row of detecting pixels), a CCD array, and/or any other suitable image-sensing device. In some examples, grating **115** and/or image sensor **120** comprise optoelectronic chips.

[0082] Compact spectrometer **100** has a high sensitivity to light, enabling it to acquire hyperspectral data in low-light environments, such as underwater. Compact spectrometer **100** also has a relatively short electro-optical integration time (e.g., it can complete a measurement in a short amount of time). As a result of its high sensitivity and short integration time, compact spectrometer **100** has a wide dynamic range. In other words, it is capable of measuring both low levels and high levels of light. The wide dynamic range of compact spectrometer **100** enables device **30** to be used in dark underwater environments as well as bright above-water environments.

[0083] Due to its small size, compact spectrometer **100** has a short optical path length. That is, light travels a relatively small distance within compact spectrometer **100**. The short optical path length allows for high stability against vibrations, thermal changes, optical defects, stray light, and/or other disruptions.

[0084] Suitable examples of compact spectrometer **100** include the compact spectrometer currently sold under the name “C12880MA” by Hamamatsu Photonics and the Carl Zeiss Spectroscopy GmbH product named “Monolithic Miniature Spectrometer, MMS UV-VIS”. Other suitable examples of compact spectrometer **100** may include a spectrometer that supports a spectral response up to 850 nm or more (e.g., a spectral domain of 300 nm to 900 nm, of 330 nm to 850 nm, and/or any other suitable range), has a maximum spectral resolution of 15 nm, is sized approximately 20×13×10 mm, and/or weighs approximately 5 grams or less. Larger size sensor modules or packages with sizes approximately 70×60×40 mm and weighing 50 grams or less may be suitable also.

C. Illustrative Devices Having a Light Source

[0085] As shown in FIGS. 4-6, this section describes illustrative hyperspectral sensing devices including light sources (e.g., LEDs, lamps, and/or lasers) and configured to illuminate a sample so that scattering, fluorescence, and/or absorption properties of the sample may be probed. These devices may be substantially similar to device **30** in at least some respects. The sample may be, e.g., a sample of air or a sample of water. In some embodiments, the sample is a defined volume of gas, liquid, or solid matter inside a container.

[0086] FIG. 4 schematically depicts a device **130** configured to illuminate a discrete and/or flow-through sample.

For example, the sample may be a discrete sample removed from the sampling site (such as a defined quantity of water removed from a body of water using, e.g., a profiling rosette, bottle, and/or other suitable device). Alternatively, or additionally, the sample may be a flow-through sample configured to be passed through the viewable region of the sensing system (for example, water may be pumped from a body of water through a sampling chamber disposed in front of the optical collector, so that a measurement or series of measurements of the flowing water may be made).

[0087] Device **130** includes a light source **136**, which comprises one or more devices configured to emit light, such as LEDs, OLEDs, diode lasers, fiber lasers, lamps, and/or the like. In some examples, the one or more light-emitting devices of light source **136** each produce light substantially at a single wavelength. For example, LEDs producing light at 405 nm, 470 nm, 560 nm, and/or 650 nm may be used. In some examples, one or more of the light-emitting devices produce light at a range of wavelengths. For example, light source **136** may include broadband LEDs (e.g., superluminescent LEDs), a continuum and/or supercontinuum source, and so on. The wavelength range of light source **136** may be selected based on specific absorbing, scattering, and/or fluorescing substances expected to be present in the sample. Light source **136** may be modulated (e.g., amplitude-modulated and/or phase-modulated) such that light from the light source may be distinguished and/or isolated from background and/or ambient light (with or without lock-in amplification).

[0088] Device **130** includes an optical assembly configured to prepare light produced by the source for transmission to the sample. Typically, the optical assembly includes a diffuser **138** configured to homogenize (e.g., diffuse) light produced by the light source, and a lens **139** configured to collimate light produced by the light source (e.g., to telecentrically illuminate the sample). These components preserve the focal plane of the light source across the sample volume.

[0089] In some examples, light source **136** and/or the associated optical assembly may be mounted detachably to device **130** so that they can be removed when not needed, or swapped out for different components.

[0090] Device **130** includes an optical collector **142** configured to collect light from the sample and to transfer it to a sensor **146** (e.g., a compact spectrometer or other suitable detector having sufficient spectral resolution for hyperspectral measurements). Collector **142** may include one or more bandpass and/or notch optical filters configured to block light produced by light source **136** that is transmitted through the sample, or passes around the sample, substantially without interacting with the sample. These filters may, for example, increase a signal-to-noise ratio of the hyperspectral measurement, and/or may prevent a weak fluorescence signal received at sensor **146** from being overwhelmed by a strong background signal from light source **136**.

[0091] In some examples, one or more optical components of collector **142** are selected based on optical properties associated with a bottle or other device containing the sample (e.g., based on an amount of refraction experienced by light passing through the bottle). Device **130** may be configured to be used with any one of a plurality of interchangeable collectors having different optical components.

[0092] FIG. 5 schematically depicts an illustrative device **150** configured to acquire hyperspectral data using a light source while immersed in a sample. For example, device **150** may be immersed in water, may be used to measure ambient air, and/or may be used in any other situation wherein the entire optical path between the light source and the optical collector is occupied by the sample. Device **150** includes a light source **156**, a light-source diffuser **158**, a light-source collimating lens **159**, an optical collector **162**, and a sensor **166**.

[0093] FIG. 6 schematically depicts an illustrative device **180** configured for selectively adjusting an angle formed by a light source **182** relative to a collector **184** and a sensor **186**. Collector **184** and sensor **186** are mounted slidably on a rail **190**, as shown in FIG. 6. Typically, collector **184** and sensor **186** are connected rigidly, such that they move together along the rail, but other configurations are possible. In a first position, the collector and sensor are disposed such that light from light source **182** passes through a sample, and light transmitted directly through the sample (e.g., without deflection) enters the collector. In the first position, collector **184** and sensor **186** face light source **182** (e.g., forming a substantially 180-degree angle with the light source) with the sample disposed between them.

[0094] With collector **184** and sensor **186** in the first position, the spectral properties of light striking the sensor can be measured and compared with known spectral properties of light source **182**, and absorbance properties of the sample may be inferred. For example, a measurement indicating that the sample preferentially absorbs light at a certain wavelength may indicate that the sample contains a substance known to absorb light at that wavelength. This type of measurement may be referred to as an attenuation measurement, because the wavelength-dependence of the attenuation of light within the sample is probed.

[0095] In a second position, collector **184** and sensor **186** are disposed at an angle less than 180° relative to light source **182**. In some cases, the angle may be less than 90°. In the second position, device **180** may measure spectral properties of light scattered from the sample. For example, sensor **186** may detect light produced by photons from light source **182** undergoing Rayleigh scattering, Raman scattering, Brillouin scattering, and/or diffuse reflection from the sample. Additionally, or alternatively, sensor **186** may detect light produced by photons from light source **182** inducing fluorescence in the sample, and/or in a constituent of the sample. The spectrum of light detected at one or more selected angles may be used to determine concentrations of specific substances within the sample (e.g., concentrations of algae within water). In some examples, hyperspectral measurements of fluorescence may indicate the size of particulates within the sample, a concentration of a specific substance within the sample, a type of substance present in the sample, and/or a physiological state of a biological species within the sample.

[0096] Collector **184** and/or sensor **186** may transition between the first and second positions by sliding along rail **190**. Additional positions along rail **190** may be possible, e.g., at angles between 0° and 180° relative to light source **182**. In some examples, the variation of the sample spectrum in response to changes in the angle subtended by the collector optical axis and the angle of the excitation source may be probed. The angular dependence of the spectrum may indicate Rayleigh scattering in the sample and therefore

may be used to detect a presence or abundance of small particles (e.g., particles <0.5 microns in size).

[0097] In some examples, collector **184** and sensor **186** are moved by an actuator, and rail **190** is a fixed armature of the actuator. The actuator may enable the collector and sensor to be positioned with high accuracy and precision for reproducible angularly-resolved measurements. In some examples, light source **182** slides along the rail while collector **184** and sensor **186** are fixed in place.

D. Illustrative Collectors for Simultaneous Measurement

[0098] With reference to FIGS. 7-14, this section describes illustrative optical collectors for use in simultaneous hyperspectral measurements of light propagating from two different directions using a single sensor (e.g., a single spectrometer). In some examples, light from one direction is propagating from the sky, and light from the other direction is propagating from a body of water. Simultaneous sky-water measurements may, for example, be used to determine spectral properties of a body of water such as an ocean, coastal region, lake, reservoir, estuary, river, and/or the like. For convenience, collectors configured for use in measurement of light from two directions are described herein in the context of simultaneous sky and water radiance measurements. However, generally, light from the two directions may have any suitable origin.

[0099] In some examples, a body of water may be characterized by a spectral remote-sensing reflectance, e.g., a wavelength-dependent ratio of radiance leaving the water in a particular viewing direction to the total sky irradiance just above the water's surface. The remote-sensing reflectance R_{rs} may be defined by the following equation:

$$R_{rs}(\theta, \varphi, \lambda) = \frac{L_w(\theta, \varphi, \lambda)}{E_d(\lambda)}$$

[0100] where $L_w(\theta, \varphi, \lambda)$ is the radiance of water-leaving light at wavelength λ in a direction defined by polar and azimuthal angles (θ, φ) and $E_d(\lambda)$ is the irradiance of downwelling light at wavelength λ incident on the water surface. Downwelling light typically includes light from the sky. Water-leaving light includes light emerging from beneath the surface of the water, such as light from the sky that traveled beneath the surface and was scattered upward through the surface. Water-leaving light by definition does not include light reflected directly from the surface of the water substantially without traveling underwater. In general, a direct measurement of the water-leaving radiance is not possible because a detector pointed at the water surface will measure the total upwelling radiance, which includes both the water-leaving radiance and the surface-reflected radiance. That is, a detector measures

$$L_T(\theta, \varphi, \lambda) = L_w(\theta, \varphi, \lambda) + L_r(\theta, \varphi, \lambda)$$

[0101] where $L_T(\theta, \varphi, \lambda)$ is the total upwelling radiance and $L_r(\theta, \varphi, \lambda)$ is the surface-reflected radiance. The water-leaving radiance may, however, be estimated from the total upwelling radiance by several methods. In some methods, the surface-reflected radiance is estimated by multiplying the sky radiance by a correction factor. For example,

$$L_r(\theta, \varphi, \lambda) = \rho L_s(\theta', \varphi', \lambda)$$

[0102] where the angles (θ', φ') denote a direction within the field of view of the detector when the detector is pointed in a direction suitable for sampling the sky radiance that would specularly reflect from the water surface into the direction defined by (θ, φ) . The correction factor ρ , which may be a Mobley surface correction, may depend on either or both angles (θ, φ) , wavelength λ , and/or other factors such as environmental factors. Using this estimate for the surface-reflected radiance, the remote-sensing reflectance may be estimated as

$$R_{rs}(\theta, \varphi, \lambda) = \frac{L_T(\theta, \varphi, \lambda) - \rho L_s(\theta', \varphi', \lambda)}{E_d(\lambda)}$$

[0103] Alternatively, or additionally, the surface correction of the sky radiance can be explicitly modeled using a bidirectional reflectance distribution function (BRDF) using the known imaging view geometry (e.g., solar zenith and azimuth angles, and sensor zenith and azimuth view angles), a model of the angle and/or wavelength-dependent reflectance at the air-water interface, and the interface roughness due to wave facets on the water surface. Alternatively, or additionally, a plurality of sensors may measure the total upwelling radiance from different angles, and the surface correction may be obtained based on the measurements. In these examples, measuring the sky radiance is optional.

[0104] The downwelling irradiance $E_d(\lambda)$ may be estimated by measuring the reflectance of a reference surface having a known reflectance parameter R_{ref} . A typical reference surface is a flat, rigid plaque configured to reflect incident light diffusely and isotropically (e.g., a Lambertian reflector). For example, a card coated with barium sulfate and/or magnesium oxide may be used as a plaque. The radiance L_{ref} of light reflected by the plaque is independent of the measurement angle and may be calculated as

$$L_{ref}(\lambda) = \left(\frac{R_{ref}(\lambda)}{\pi} \right) E_d(\lambda)$$

The remote-sensing reflectance for a given wavelength in a given direction may be calculated from the measured total upwelling radiance, the measured sky radiance, and the measured reference plaque reference:

$$R_{rs} = \frac{(L_T - \rho L_s)}{\pi(L_{ref} / R_{ref})}$$

[0105] In other examples, the downwelling irradiance may be measured directly.

[0106] In known systems for remote-sensing radiance measurements, the sky radiance and the total upwelling radiance are typically measured in sequence with a single detector or simultaneously with multiple respective detectors. (The reference plaque, if used, may be measured at the same time as the total upwelling radiance, or may be measured independently.) Both sequential measurements and multiple-detector measurements have disadvantages. Environmental conditions may change significantly between sequential measurements, leading to uncertainty and/or noise in the measured data. Data acquired by multiple

detectors may include errors due to the detectors having different sensitivities, being imperfectly calibrated, and/or triggering data acquisition at slightly different times. Systems and methods of the present disclosure allow simultaneous measurement of the total upwelling radiance, sky radiance, and optionally a reference plaque radiance, using a single hyperspectral-capable sensor (e.g., a single compact spectrometer).

[0107] Illustrative sky-water collectors configured to collect light for a simultaneous sky-water measurement are described below. As defined herein, a simultaneous sky-water measurement is a substantially simultaneous measurement of total upwelling radiance and sky radiance, and may include a substantially simultaneous or a non-simultaneous measurement of a reference plaque. An illustrative sky-water collector **250** is depicted schematically in FIG. 7. Sky-water collector **250** includes a sky-radiance aperture **254** configured to allow light to enter the collector, a water-radiance aperture **256** configured to allow light to enter the collector, and an optical director **258** (e.g., an assembly of optical components) configured to direct light entering through the sky-radiance aperture and light entering through the water-radiance aperture toward a sensor within the device. Sky-radiance aperture **254** and water-radiance aperture **256** may include slits of fixed or variable width, optical diffusers, lenses, and/or other optical components. Optionally, sky-water collector **250** may include steering optics (e.g., mirrors, filters, polarizers, polarizing and/or nonpolarizing beamsplitters, and/or other steering components) configured to direct light in one or more directions, refractive and/or diffractive elements configured to adjust beam sizes and/or shapes of light, beam blocks configured to block light from entering one or more portions of the collector, and/or modulators configured to modulate light (e.g., to modulate a phase and/or amplitude of light).

[0108] Optionally, a modulator **259** may be disposed between sky-radiance aperture **254** and optical director **258** and configured to modulate light entering through sky-radiance aperture **254**, such that the portions of light entering the collector through that aperture may be distinguished. Additionally, or alternatively, a modulator may be disposed between water-radiance aperture **256** and optical director **258**.

[0109] Modulator **259** may comprise any suitable system or device configured to modulate light. In some examples, modulator **259** includes a scanning optical element configured to periodically deflect light such that at least a portion of the light deviates from the optical path it would otherwise travel. For example, a scanning mirror may periodically deflect the light such that the light is not directed toward a sensor, or such that the light strikes a beam block within sky-water collector **250**.

[0110] Additionally, or alternatively, modulator **259** may comprise a chopper wheel **260**. Chopper wheel **260**, depicted in FIG. 8, includes an opaque substrate (e.g., a disc) having openings **261** at regular angular intervals. Adjacent openings **261** are separated by unmodified blocking portions **262** of the opaque substrate. Chopper wheel **260** is rotatably mounted to a support and configured to rotate at a fixed, stable rate (e.g., a motor may drive the chopper wheel to rotate at a specific speed). Light may be amplitude-modulated by placing chopper wheel **260** in the optical path of the light. As chopper wheel **260** rotates, the light is periodically blocked by blocking portions **262** and allowed to pass by

intervening openings **261**. The periodic blocking effectively modulates the amplitude of the light.

[0111] In examples including modulation of light entering through one or more apertures, an electronics module (e.g., electronics module **70**) may be configured to trigger data acquisition by the sensor in phase (and frequency) with the modulation cycle of the modulator. For example, data acquisition may be triggered in phase with the blocking of the incoming light by chopper wheel **260**, or in phase with the passing of the light through openings **261** of chopper wheel **260**. In this way, data acquired by the sensor when one or more apertures are blocked by chopper wheel **260** may be compared with data acquired when no apertures are blocked by chopper wheel **260**, and so the contribution of light from each aperture may be identified. In some examples, a lock-in amplifier is used to selectively amplify the modulated signal and reject any signals that do not vary with the phase and/or frequency associated with the modulator.

[0112] Although sky-water collectors disclosed herein are primarily described as enabling measurement of light from sky and from water simultaneously, they may be used to simultaneously measure light from any two suitable sources. For example, a sky-water collector may be included in a hyperspectral sensing device deployed underwater, and the sky-water collector may collect light originating near the floor of the body of water and light originating near the surface of the body of water. In this manner, the hyperspectral sensing device may simultaneously measure radiances of floor light and surface light. Illustrative examples of sky-water collectors are described below. Various components of the illustrative sky-water collectors described below may be combined in any suitable combination.

i. Illustrative Convex Reflector Collector

[0113] An illustrative convex reflector collector **270** is depicted in FIG. **9**. Convex reflector collector **270** is an example of sky-water collector **250**. Convex reflector collector **270** includes a convex reflector **272**, which is an example of optical director **258**. Convex reflector **272** is a curved reflective element configured to direct light entering convex reflector collector **270** toward the sensor. Convex reflector **272** may focus light at a primary focus point between the convex reflector and the sensor. Sky-radiance aperture **254**, water-radiance aperture **256**, and convex reflector **272** are disposed such that light entering through the water-radiance aperture and light entering through the sky-radiance aperture reflect from the convex reflector along substantially parallel optical paths and/or substantially overlapping optical paths (e.g., light from the two apertures may co-propagate after reflecting from the convex reflector). Modulator **259** may be disposed adjacent one of the apertures such that light entering the aperture is modulated prior to reflecting from convex reflector **272**. In the example depicted in FIG. **9**, modulator **259** is disposed exterior to sky-radiance aperture **254**, but modulators may additionally or alternatively be disposed interior to the sky-radiance aperture, and/or exterior and/or interior to water-radiance aperture **256**. For example, modulator **259** may be disposed interior to the sky-radiance aperture, such that modulator **259** is disposed between the sky-radiance aperture and convex reflector **272**.

ii. Illustrative Movable Reflector Collector

[0114] An illustrative movable reflector collector **280** is depicted in FIG. **10**. Movable reflector collector **280** is an example of sky-water collector **250**. Movable reflector col-

lector **280** includes a movable reflector **282**, which is an example of optical director **258**. Movable reflector **282** comprises a reflective optical element mounted rotatably within movable reflector collector **280**. Movable reflector **282** may additionally or alternatively be mounted translatably within movable reflector collector **280**. Movable reflector **282**, sky-radiance aperture **254**, and water-radiance aperture **256** are disposed within movable reflector collector **280** such that positioning the movable reflector at a first position (e.g., a first orientation) causes light entering from the sky-radiance aperture to be reflected toward sensor **40** and light entering from the water-radiance aperture to be reflected away from the sensor, and positioning the movable reflector at a second position causes light entering from the sky-radiance aperture to be reflected away from the sensor and light entering from the water-radiance aperture to be reflected toward the sensor. The position of movable reflector **282** may be adjusted very quickly to switch between measurements of sky radiance and water radiance, and no other component of movable reflector collector **280** requires adjustment to switch from sky to water radiance measurements. Therefore, movable reflector collector **280** may be described as capable of substantially simultaneous measurements of sky and water radiance.

[0115] One or more beam blocks **284** configured to substantially prevent transmission and specular reflection of impinging light may be disposed within movable reflector collector **280** to block light that is not directed toward the sensor. Use of beam blocks **284** may reduce stray light reaching the sensor and thereby decrease noise and uncertainty in the hyperspectral measurement. Movable reflector collector **280** may include one or more modulators **259**.

iii. Illustrative Movable Disperser Collector

[0116] An illustrative movable disperser collector **290** is depicted in FIG. **11**. Movable disperser collector **290** is an example of sky-water collector **250**. Movable disperser collector **290** includes a movable dispersing element **292**, which is an example of optical director **258**. Movable dispersing element **292** is a dispersing optical element (e.g., a prism, grating, and/or any other suitable element configured to direct light in a wavelength-dependent direction) mounted rotatably within movable disperser collector **290**, and may additionally or alternatively be mounted translatably within the collector. Movable dispersing element **292**, sky-radiance aperture **254**, and water-radiance aperture **256** are disposed within movable disperser collector **290** such that positioning the movable dispersing element at a first position (e.g., a first orientation) causes light entering from the sky-radiance aperture to be reflected toward the sensor and light entering from the water-radiance aperture to be reflected away from the sensor, and positioning the movable dispersing element at a second position causes light entering from the sky-radiance aperture to be reflected away from the sensor and light entering from the water-radiance aperture to be reflected toward the sensor. Beam blocks **284** may be disposed within movable disperser collector **290** to block stray light from the detector. Modulator **259** may be included. Because movable dispersing element **292** spatially separates light according to wavelength, dispersing elements typically included in the sensor may be omitted when movable disperser collector **290** is used. For example, the sensor may comprise replaced by a linear CMOS or CCD array rather than a spectrometer.

iv. Illustrative Beamsplitter Collector

[0117] An illustrative beamsplitter collector **300** is depicted in FIG. 12. Beamsplitter collector **300** is an example of sky-water collector **250**. Beamsplitter collector **300** includes a beamsplitter **302** configured to combine light impinging on the beamsplitter from two or more directions into a single copropagating beam of light. Typically, beamsplitter **302** is configured to reflect a portion of incoming light and to transmit a portion of incoming light. Beamsplitter **302** may comprise a partially reflecting mirror, a beamsplitter cube, a fiber-optic beamsplitter, a half-silvered mirror, a pellicle (e.g., a thin membrane), a waveguide beamsplitter, and/or a micro-optic beam splitter. Beamsplitter **302**, sky-radiance aperture **254**, and water-radiance aperture **256** are disposed within beamsplitter collector **300** such that light from the sky-radiance aperture and light from the water-radiance aperture impinge on the beamsplitter from different directions and are emitted by the beamsplitter in the same direction toward the sensor. One or more transmissive polarizing elements (e.g. a wire-grid polarizer, a quarter-wave plate, etc.) and/or reflective polarizing elements (e.g., a thin film, another beamsplitter, etc.) may be disposed between beamsplitter **302** and sky-radiance aperture **254**, and/or between beamsplitter **302** and water-radiance aperture **256**, to polarize the light. The polarizing elements may polarize the light linearly, circularly, and/or elliptically. Beamsplitter **302** may be a polarizing beamsplitter, and the polarizing elements may be configured to polarize the sky light and/or water light such that substantially all of the sky light and water light is combined at the beamsplitter and directed toward the sensor. Additionally, beam blocks, mirrors and/or other suitable reflectors, and/or modulators may be included as needed.

v. Illustrative Sky-Water-Plaque Collector

[0118] An illustrative sky-water-plaque collector **310** is depicted in FIG. 13. Sky-water-plaque collector **310** is configured to collect light from the sky, from the water, and from a reference plaque substantially simultaneously. Sky-water-plaque collector **310** includes a first optical assembly **311** configured to combine two sources of light (e.g., from the sky and from the plaque, from the sky and from the water, or from the water and from the plaque) into a first light combination, and to transmit the first light combination to a second optical assembly **312** configured to combine the first light combination with a third source of light (e.g., light from a source not included in the first light combination) to produce a second light combination including light from all three sources. In the example depicted in FIG. 13, the first and second optical assemblies comprise beamsplitters, but any suitable combination of optical elements may be included. One or more polarizing elements **315** may be included to polarize light such that it is reflected by, or transmitted by, a polarizing beamsplitter in first optical assembly **311**. Additionally, or alternatively, polarizing elements may be configured to polarize light such that it is reflected or transmitted by second optical assembly **312**, and/or any other suitable optical component(s). Mirrors and/or polarizing reflectors may be used to steer the first light combination toward second optical assembly **312** and/or to steer the second light combination toward the sensor. Any one or more of the sky light, plaque light, and water light may be independently modulated with a modulation

depth, frequency, and/or pattern configured to enable the light from the different sources to be distinguished from each other.

vi. Illustrative Sequential Plaque Collector

[0119] An illustrative sequential plaque collector **320** is depicted in FIG. 14. Sequential plaque collector **320** includes a sky-water collector **250** (e.g., beamsplitter collector **300**) and further includes an alternating element **322** configured to selectively direct sky light or plaque light into an entrance aperture of the collector. For example, alternating element **322** may include a reference plaque and a mirror, either or both of which are movable. The mirror may be moved in front of the plaque such that it substantially blocks light reflected by the plaque from entering the entrance aperture and reflects sky light into the entrance aperture, or moved away from the plaque such that light reflected by the plaque may enter the aperture. The mirror and/or the plaque may be disposed on translation stages that are manually movable and/or motorized. The mirror and/or the plaque may be mounted rotatably, such that the mirror may be rotated in front of the plaque for a sky radiance measurement and rotated away from the plaque for a plaque radiance measurement. Water light enters sequential plaque collector **320** through a second entrance aperture (e.g., water-radiance aperture **256**) regardless of the position of alternating element **322**. A simultaneous measurement of water-radiance and sky-radiance may therefore be followed immediately by a simultaneous measurement of water-radiance and plaque-radiance. The time between the first simultaneous measurement and the second simultaneous measurement is so short (due to the speed at which alternating element **322** may be moved, as well as time characteristics of the associated sensor) that the first and second measurements may be considered nearly simultaneous with each other for many purposes. For example, atmospheric conditions such as cloud cover are likely to change very little between the first and second measurements.

[0120] In the example depicted in FIG. 14, alternating element **322** alternately allows sky light or plaque light to enter a first aperture, while water light is never prevented from entering a second aperture. In other examples, alternating element **322** alternately allows water light or plaque light to enter the first aperture, while sky light is never prevented from entering the second aperture.

[0121] Alternating element **322** may be added to any suitable sky-water collector **250** (e.g., exterior to the sky-radiance aperture **254** or water radiance aperture **256**) to make a sequential plaque collector

E. Illustrative Network of Hyperspectral Sensing Devices

[0122] With reference to FIG. 15, this section describes an illustrative hyperspectral sensing system **350** in accordance with aspects of the present teachings.

[0123] As depicted schematically in FIG. 15, system **350** comprises a plurality of hyperspectral sensing devices **355**. Devices **355** may comprise and/or be similar to device **30** and/or any other suitable devices. Devices **355** may be distributed across any suitable area. In some examples, devices **355** are distributed adjacent to, on, and/or in a body of water (e.g., above water, underwater, on coasts, on buoys, on weather stations, and/or in any similar location). Additionally, or alternatively, devices **355** may be distributed on land, on aerial vehicles, on weather balloons, and/or in any suitable location. Each device **355** is configured to acquire

hyperspectral data and to transmit the acquired data to a location remote from the device. Although a selected number of devices is shown in FIG. 15, more or fewer devices may be utilized, and system 350 may include different numbers of devices at different times. In some examples, subsets of devices within the system may be collocated.

[0124] Each device 355 is configured to communicate with a computer network 360 via a wireless communications module of the device (e.g., input/output hub 80, described above). Computer network 360 may be configured to communicate data (e.g., to transmit data to and/or receive data from) a server 365 and/or any other suitable device. Communication between devices 355 and computer network 360, and/or between the network and server 365, may comprise radio frequency (RF) antenna, GSM (Global System for Mobile Communications)/GPRS (General Packet Radio Service) cellular modem, Bluetooth® wireless technology, WiFi, and/or any other suitable protocol.

[0125] Typically, devices 355 are configured for autonomous operation. In this mode, the devices transmit acquired data to server 365 via computer network 360 at selected intervals (e.g., on a predetermined schedule, in response to the acquired data meeting one or more criteria, and/or at any other suitable time). For example, data may be transmitted daily, several times per day, in real-time or near real-time (e.g., approximately every 10-15 minutes), and/or at any other suitable interval.

[0126] In some examples, server 365 transmits data and/or instructions to one or more of the devices (e.g., to an input/output hub of a device). These communications from server 365 may include software and/or firmware updates, operating settings (e.g., sample rates, sample intervals, integration times, types of data, etc.), calibration routines, and/or data transfer protocols of the devices. Additionally, or alternatively, server 365 may synchronize clocks of the devices, manage power settings of the devices, and/or trigger specific routines (e.g., calibration).

[0127] In some examples, devices 355 are each configured to communicate with one or more of a plurality of different servers using one or more parallel networks.

[0128] In examples wherein each device 355 includes two or more sensors (e.g., two or more spectrometers, or at least one spectrometer and at least one auxiliary sensor), any suitable electronics on board the device may be used to operate the sensors and to transmit the acquired data. For example, the device may include a dedicated microcontroller or other processing logic for each of the sensors. Alternatively, a single microcontroller may be configured to control all sensors, or a plurality of the sensors. In some examples, a data processing system on board the device may be configured to control the sensors and/or to control communication with network 360.

[0129] In cases wherein data from the two or more sensors is combined, the data may be transmitted to server 365 independently and combined after transmission to reduce power usage of the local electronics module. However, in some cases, data from multiple sensors is combined prior to transmission to reduce transmission bandwidth.

F. Illustrative Method for Sky-Water Measurement

[0130] This section describes steps of an illustrative method 400 for simultaneous or near-simultaneous measurement of a combination of sky radiance, water radiance, and/or plaque radiance; see FIG. 16. Aspects of sky-water

collectors 250 may be utilized in the method steps described below. Where appropriate, reference may be made to components and systems that may be used in carrying out each step. These references are for illustration, and are not intended to limit the possible ways of carrying out any particular step of the method.

[0131] FIG. 16 is a flowchart illustrating steps performed in an illustrative method, and may not recite the complete process or all steps of the method. Although various steps of method 400 are described below and depicted in FIG. 16, the steps need not necessarily all be performed, and in some cases may be performed simultaneously or in a different order than the order shown.

[0132] At step 402, the method includes receiving a first portion of light in an optical collector of a hyperspectral sensing system (e.g., hyperspectral sensing device 30). For example, the first portion of light may be light from the sky above a body of water. The first portion of light may be received via a first entrance aperture of the optical collector.

[0133] At step 404, the method optionally includes modulating the first portion of light. For example, the first portion of light may be amplitude-modulated using a chopper wheel.

[0134] At step 406, the method includes receiving a second portion of light in the optical collector, e.g., via a second entrance aperture of the optical collector. For example, the second portion of light may be light upwelling from a body of water.

[0135] At step 408, the method optionally includes modulating the second portion of light, e.g., using a chopper wheel.

[0136] At step 410, the method optionally includes receiving a third portion of light in the optical collector. The third portion of light may be received via a third entrance aperture of the collector. The third portion of light may be light reflected from a reference plaque.

[0137] At step 412, the method optionally includes modulating the third portion of light. If more than one of the first, second, and third portions of light are modulated, they are modulated in different patterns. For example, they may be modulated with chopper wheels 260 having openings of different sizes, having blocking portions of different sizes, and/or having different speeds of rotation. The different modulation enables the measurements of the first, second, and third light portions to be distinguished from each other, e.g., as described above with reference to chopper wheel 260.

[0138] At step 414, the method includes directing the first portion of light toward a sensor (e.g., toward an entrance aperture of sensor 40 and/or toward an imaging detector such as a CCD or CMOS array). At step 416, the method includes directing the second portion of light toward the sensor. At step 418, the method optionally includes directing the third portion of light, if it is present, toward the sensor. Directing any one of the portions of light toward the sensor may include reflecting the light from a reflective optical element, dispersing the light with a dispersive optical element, and/or diffracting the light with a diffractive optical element. Directing the portions of light toward the sensor may include combining one or more portions of light using a polarizing or nonpolarizing beamsplitter. Combining one or more portions of light using a polarizing beamsplitter may include polarizing at least one of the portions of light (e.g., using a wire-grid polarizer, quarter-wave plate, and/or thin-film polarizer) such that it reflects from the beamsplitter and

is combined with at least one portion of light that impinges on the beamsplitter from another direction and is transmitted. In some cases, two portions of light may be combined first and subsequently combined with the third portion of light. In some examples, directing the first, second, and/or third portion of light toward the sensor includes adjusting a position of an optical element, such as a rotatable mirror. In some embodiments, steps 402 and 414 may be performed simultaneously and/or before step 406.

[0139] At step 420, the method includes measuring a spectrum of light impinging on the sensor. The impinging light typically includes the first, second, and/or third portions of light directed toward the sensor in steps 414-418. Measuring a spectrum of the light may include using a transducer configured to convert intensity of received light into an electrical voltage or current signal readable by an electronics module. In some examples, measuring a spectrum of the impinging light may include dispersing the impinging light with a dispersive optical element such as a blazed grating, such that spectral components of the impinging light are spatially separated. Measuring the spectrum may further include measuring an intensity of light at a variety of spatial points (e.g., using a CMOS linear array) and converting the spatial points into spectral information.

[0140] At step 422, the method optionally includes logging the measured data (e.g., the voltage signals read by the electronics module) in a volatile or nonvolatile storage medium (e.g., a memory) associated with the hyperspectral sensor. Alternatively, or additionally, the measured data may be transmitted to an external device.

G. Illustrative Method for Hyperspectral Measurements Using a Light Source

[0141] This section describes steps of an illustrative method 500 for hyperspectral measurements of absorption, fluorescence, luminescence, and/or scattering; see FIG. 17. Aspects of hyperspectral sensing device 30 may be utilized in the method steps described below. Where appropriate, reference may be made to components and systems that may be used in carrying out each step. These references are for illustration, and are not intended to limit the possible ways of carrying out any particular step of the method.

[0142] FIG. 17 is a flowchart illustrating steps performed in an illustrative method, and may not recite the complete process or all steps of the method. Although various steps of method 500 are described below and depicted in FIG. 17, the steps need not necessarily all be performed, and in some cases may be performed simultaneously or in a different order than the order shown.

[0143] At step 502, the method includes positioning a sample, a light source, and an optical collector of a hyperspectral sensing system. The collector may comprise a slit of fixed width, and may further include optical components as discussed elsewhere herein. Positioning the sample, the light source and the collector may include immersing the light source and/or collector in water (e.g., placing the collector and light source underwater). In this case, the hyperspectral measurements are made underwater, and the water may be the sample. In some examples, the sample is between the light source and the collector. In some examples, the light source and the collector form a desired angle with sample, which may be an acute angle (e.g., to enable back-scattering measurements).

[0144] In some examples, step 502 includes disposing one or more tagging agents in the sample (e.g., biologically and/or chemically altering the sample by addition of the tagging agents). Tagging agents are configured to bind with specific predetermined substances such as biological cells, sub-cellular structures, sub-sub-cellular structures and/or compounds (e.g., proteins), and to exhibit identifiable wavelength-dependent luminescent and fluorescent signatures (e.g., in response to illumination by a suitable light source). The addition of tagging agents to the sample thus enables the identification of the tagged substances (e.g., a specific cellular species) and/or determination of the abundance, mass, or density of the tagged substance based on the intensity of the fluorescence, the volume of the sample throughout which the tagging agents are distributed, and/or any other suitable factors. Suitable tagging agents may include lanthanides and/or any other suitable reagents.

[0145] At step 504, the method includes illuminating the sample with the light source. The light source may be an LED, laser, lamp, and/or any other suitable device configured to emit light. In some examples, the light source is modulated.

[0146] At step 506, the method includes receiving light propagating from the sample using the collector. The collector may receive light propagating from the sample along a predetermined direction and/or within a predetermined solid angle. Receiving light propagating from the sample may include receiving light that originated in the light source and was scattered elastically or inelastically from the sample, was reflected from the sample, and/or was transmitted through the sample, and/or may include receiving light that was produced by fluorescence within the sample (e.g., by substances within the sample, by tagging agents within the sample, etc.). The collector may be configured to attenuate and/or block light received directly from the light source.

[0147] At step 508, the method includes measuring a spectrum of the received light. Measuring a spectrum of the received light may include directing the light toward a sensor, such as a compact spectrometer, using the collector.

[0148] At step 510, the method optionally includes logging the measured data in a memory device of the hyperspectral sensing system.

H. Illustrative Method for Assessing Water Quality

[0149] This section describes steps of an illustrative method 600 for assessing water quality; see FIG. 18. Aspects of hyperspectral sensing systems and devices described above may be utilized in the method steps described below. Where appropriate, reference may be made to components and systems that may be used in carrying out each step. These references are for illustration, and are not intended to limit the possible ways of carrying out any particular step of the method.

[0150] FIG. 18 is a flowchart illustrating steps performed in an illustrative method, and may not recite the complete process or all steps of the method. Although various steps of method 600 are described below and depicted in FIG. 18, the steps need not necessarily all be performed, and in some cases may be performed simultaneously or in a different order than the order shown.

[0151] A step 602, the method includes receiving ambient light through a first aperture of a housing of an optical device (e.g., device 30) disposed adjacent a surface of a body of

water. The first aperture may be, e.g., the aperture of an optical collector of the device. The first aperture is directed at the surface of the body of water, such that light received through the first aperture includes light reflected from the surface and light passing through the surface from underneath.

[0152] At step **604**, the method includes receiving ambient light through a second aperture of the housing, the second aperture being directed at the sky. Light received from the second aperture therefore includes light coming from the sky. The second aperture may be, e.g., a second aperture of an optical collector of the device, which may be the same collector that includes the first aperture, or a different collector of the device. Receiving light at step **602** and/or step **604** may include modulating the received light (e.g., to facilitate distinguishing measurements of the light received through the different apertures).

[0153] At step **606**, the method includes directing light received from the first and second apertures into a sensor assembly disposed within a housing of the device. The light may be directed by any suitable optical assembly. In some examples, the sensor assembly includes a first spectrometer for sensing light received through the first aperture and a second spectrometer for sensing light received through the second aperture. Alternatively, the sensor assembly may comprise only one spectrometer, and light received through either aperture is directed to the same spectrometer. In the latter case, light from the two apertures may be directed simultaneously or sequentially to the common spectrometer (e.g., using aspects of illustrative sky-water collectors describe above).

[0154] At step **608**, the method includes sensing, using the sensing assembly, data corresponding to a spectrum of the light received from the first and second apertures. The spectrometer(s) of the sensing assembly have sufficient spectral resolution to enable hyperspectral measurements. The data may be sensed simultaneously or sequentially.

[0155] At step **610**, the method optionally includes sensing data corresponding to a spectrum of light reflected by a reference plaque. As described in Section D, a reference plaque typically comprises a flat, rigid surface having known reflectance properties and configured to reflect incident light diffusely and isotropically (e.g., a Lambertian reflector). Accordingly, with the reference plaque positioned above the surface of the water, a spectrum of light reflected from the sensing plaque may be used to determine wavelength-dependence of the irradiance of downwelling light from the sky in all directions. This may be used to calculate a remote-sensing reflectance (e.g., a measure of how much of the radiance traveling in all downward directions is reflected upward into any direction), and/or any other suitable property. Sensing data corresponding to the spectrum reflected by the reference plaque typically includes receiving data light reflected by the reference plaque through any suitable aperture of the device, including the first or second apertures, and sensing the spectrum using any suitable spectrometer.

[0156] At step **612**, the method includes determining, based on the sensed data, a spectrum of light originating underneath the surface of the water (e.g., water-leaving light). For example, a remote-sensing reflectance may be calculated based on the following equation:

$$R_{rs} = \frac{(S_T - \rho(\theta)S_s)}{\pi(S_{ref} / R_{ref})}$$

[0157] In this equation, S_T represents a measured signal of light received through the first aperture (the water-directed aperture), S_s represents a measured signal of light received through the second aperture (the sky-directed aperture), S_{ref} represents an average measured signal from a reference plaque, and R_{ref} represents a reflectivity of the plaque. The measured signal from the second aperture is multiplied by $\rho(\theta)$, a proportionality factor relating radiance measured when the detector views the sky to the reflected sky radiance measured when the detector views the sea surface. The value of this proportionality factor may depend on wind speed and direction, detector field of view, and sky radiance distribution. The proportionality factor may be a Mobley proportionality factor. The factor of π converts the reflected plaque radiance to an irradiance (e.g., it converts direction-dependent data to direction-independent data). Alternatively, or additionally, calculating the remote-sensing reflectance may include determining a surface correction of the radiance received through the sky-directed aperture based on a bidirectional reflectance distribution function.

[0158] As described above in Section D, the remote-sensing reflectance obtained by this calculation comprises information about a spectrum of light originating underneath the surface of the water (e.g., the water-leaving light); specifically, the remote-sensing reflectance is a wavelength-dependent ratio of radiance leaving the water in a particular viewing direction to the total sky irradiance just above the water's surface. Accordingly, the remote-sensing reflectance may be used to infer information about, e.g., biological, chemical, and/or geological constituents in the water containing substances (e.g., pigments) that alter optical properties of the water. In other examples, a spectrum of light originating underneath the surface of the water may be obtained in another way.

[0159] As described above, in some examples light received through the first and second apertures are measured by a same spectrometer, possibly simultaneously. In other words, a signal measured by the spectrometer includes contributions from light received through the first aperture and contributions from light received through the second aperture. In these examples, determining a spectrum of water-leaving light at step **612** includes distinguishing the two contributions (e.g., to obtain the signals S_T and S_s described above). Typically, distinguishing the two contributions is facilitated by modulating the light received through one or both apertures (e.g., prior to measuring the light with the spectrometer), as described above with reference to steps **602** and **604**. As an example, if the light is modulated such that light from one aperture is periodically blocked (or otherwise prevented from reaching the spectrometer), the two contributions may be distinguished by subtracting a spectrum obtained when light from one aperture is blocked from a spectrum obtained when neither aperture is blocked. For example, the spectrum of light received through the sky-directed aperture could be subtracted from the combined spectrum of light received through both apertures. Typically, light received through one aperture (usually the sky-directed aperture) has a higher intensity than light received through the other aperture, and subtracting the higher of the two signals from the combined

signal may increase the accuracy of the calculation. The subtraction may be performed by hardware and/or software.

[0160] Additionally, or alternatively, the contributions from the sky-directed aperture and the water-directed aperture may be separated using differential spectral and/or a filter configured to selectively reject and/or transmit one or both contributions based on a frequency and/or phase of modulation. In some cases, a lock-in amplifier may be used to isolate one of the contributions, based on the frequency and/or phase of modulation. In some cases, light received through one or both apertures is wavelength-modulated (e.g., using a movable dispersing element) to facilitate separation of the two signals using a spectral filter. Based on known properties of the wavelength modulator, the measured wavelength-modulated spectra can be corrected. These techniques may be implemented in hardware and/or software.

[0161] Any processing performed to distinguish the two contributions may be performed on board the device or on an external data processing system (or other suitable device).

[0162] At step 614, the method optionally includes using the sensed data and/or the determined spectrum of water-leaving light to update remote-sensing data of the same body of water obtained by an airborne device. Remote-sensing data (e.g., wavelength-dependent reflectances of ground and/or bodies of water) obtained by an airborne device (e.g., a satellite, aircraft, unmanned aerial vehicle, and/or the like) commonly includes inaccuracies due to the passage of the sensed light through the atmosphere. Clouds, turbulence, and/or other aspects of the atmosphere may distort the light as it travels from the ground to the airborne device, such that the measured light does not accurately represent optical properties of the ground and/or water being surveyed. Additionally, an airborne device positioned high above the surface of the Earth may have a lower temporal, spatial, and/or spectral resolution than an instrument disposed nearer the ground. Accordingly, the remote-sensing data obtained by the airborne device may be cross-referenced with the spectrum obtained at step 612 to correct inaccuracies in the remote-sensing data. Corrections obtained in this manner may be extrapolated to remote-sensing data obtained in areas where no other data is available.

[0163] As an alternative, or addition, to the above method, a plurality of optical devices may be disposed adjacent the surface of the body of water, with each device having a respective aperture pointed at approximately a same portion of the surface. The devices, or collecting optics of the devices, are positioned such that each of the respective apertures is directed at the surface at a different orientation (e.g., at different angles relative to azimuth and/or zenith, resulting in a different viewing geometry). Data corresponding to a spectrum of light received through each aperture is sensed by sensing assemblies of the devices. Based on the sensed data, a spectrum of light originating underneath the surface of the water is determined. For example, a total downwelling irradiance from the sky may be collected (e.g., using a diffuser/cosine corrector and/or reflectance plaque), and the water-leaving radiance may be calculated based on data sensed by the surface-directed devices and the total downwelling irradiance.

[0164] Calculating the water-leaving radiance may include, e.g., modeling a bidirectional reflectance distribution function for the surface of the water. The bidirectional reflectance distribution function may be determined based

on, e.g., the solar zenith and azimuth (determined by measurements, date and time and geographic position of measurement, and/or any other suitable factors), device zenith and azimuth, field of view, surface roughness (based e.g. on wind speed), and a suitable model of light behavior at the water-sky interface. A suitable model of light behavior at the water-sky interface may include, e.g. transmittance and reflectance amplitudes, phase, and polarization at the interface based on Fresnel equations, Maxwell's equations, and/or any other suitable model.

[0165] Based on the bidirectional reflectance distribution function of the surface, the amount of surface-reflected radiance that each device is theoretically expected to measure may be calculated. This theoretical prediction may be compared to the radiance actually measured by each device, which includes both surface-reflected radiance and water-leaving radiance. Based on the theoretical prediction, the differences in signals measured by the devices viewing the same portion of the surface from different directions may be used to obtain an estimate of the contribution of the surface-reflected radiances to the measured signals. Based on this estimate, the water-leaving radiance corresponding to each device is calculated (e.g., by subtracting the estimated surface-reflection contributions from the measured signals). The remote-sensing reflectance corresponding to each device may be obtained by dividing the water-leaving radiance by the total sky irradiance.

[0166] Alternatively, the water-leaving radiance may be calculated without an explicit model of the bidirectional reflectance distribution function for the surface of the water. For example, the relationship between the upwelling radiances measured by the plurality of devices may be estimated (based on, e.g., the measurement angles of the devices), and this relationship may be used to estimate the water-leaving radiance. Estimating the relationship between the measured upwelling radiances may include using a linear or nonlinear fit on the measured data and/or a simulation predicting the radiances. In some examples, at least two of the devices are configured to have viewing angles at which the water-leaving radiances are predicted (e.g., by angular symmetry at a given time of day and location) to be substantially equal. This may simplify the calculation of the relationship between the measured radiances.

[0167] According to this method, no sky-directed aperture is required, though one may optionally be used.

I. Illustrative Method for Acquiring Hyperspectral Data Above Water and Underwater

[0168] This section describes steps of an illustrative method 700 for acquiring hyperspectral data above water and underwater using a single device; see FIG. 19. Aspects of hyperspectral sensing systems and devices described above (e.g., device 30) may be utilized in the method steps described below. Where appropriate, reference may be made to components and systems that may be used in carrying out each step. These references are for illustration, and are not intended to limit the possible ways of carrying out any particular step of the method.

[0169] FIG. 19 is a flowchart illustrating steps performed in an illustrative method, and may not recite the complete process or all steps of the method. Although various steps of method 700 are described below and depicted in FIG. 19, the

steps need not necessarily all be performed, and in some cases may be performed simultaneously or in a different order than the order shown.

[0170] At step 702, the method includes positioning a hyperspectral sensing device underwater. Typically, the entire device is immersed in water (e.g., in a body of water such as an ocean), but in some examples, only a portion of the device is immersed (e.g., the optical collector). The device typically includes a wireless communications module and a power supply. Accordingly, when the device is deployed underwater, it need not be connected by a power cable or data cable to another platform or device (e.g., a ship on the water's surface). This reduces the risk that another platform or device will cast a shadow over the area being sampled, or otherwise interfere with the sample.

[0171] At step 704, the method includes acquiring a first portion of hyperspectral data underwater. Acquiring the data typically includes collecting light (e.g., ambient light) with a collector of the device and transferring the collected light to a suitable sensor of the device (e.g., a compact spectrometer). Acquiring the data may further include scanning a region or object of interest (e.g., by adjustment of the collector to collect light from different spatial areas or directions, by transporting the device on an underwater vehicle such that the collector collects light from different areas, and/or the like).

[0172] At step 706, the method includes positioning the device above water (e.g., moving the device from an underwater position to an above-water position). The above-water position may comprise a ship, buoy, platform, shore, or other suitable location near the water. Alternatively, the above-water position may be located far from the water in which the device had been immersed. In some examples, the above-water position is in the air (e.g., with the device mounted on an unmanned aerial vehicle or other suitable device).

[0173] At step 708, the method includes acquiring a second portion of hyperspectral data above water. Acquiring the data includes collecting light and may include scanning a region or object of interest, as described above with reference to step 704. The sensor of the device is configured to acquire data both underwater and above-water. For example, the sensor is sufficiently sensitive to acquire data with a suitable signal-to-noise ratio in underwater environments, which are typically associated with low light levels, and is also capable of acquiring data in bright above-water environments (e.g., the sensor has a high dynamic range). In some examples, one or more settings of the sensor and/or collector are changed for the acquisition of the second portion of data. For example, an integration time, sampling rate, aperture size, filter selection, and/or other suitable parameter may be different when the device acquires data above water compared to when the device acquires data underwater. Such a parameter may be varied automatically by a controller on board the device (e.g., in response to measuring a higher light level, lower external pressure, and/or other suitable indication) and/or may be changed by a user (e.g., a user communicating with the controller via an external computer). In some cases, the collector used underwater is replaced with a different collector when the device is removed from the water, but the same spectrometer is used in both environments.

[0174] At step 710, the method optionally includes logging the acquired first and second data portions on a memory store of the device.

[0175] In some examples, steps 706-708 are performed prior to steps 702-704. That is, the above-water measurements may be performed prior to immersing the device in water and performing the underwater measurements.

[0176] In some examples, the steps of positioning the device above water and positioning the device underwater include deliberately moving the device to selected locations. Alternatively, these steps may occur automatically as the device is immersed in water due to changing environmental conditions. For example, the device may be disposed on a platform that is sometimes immersed in water (e.g., due to changing tides).

J. Illustrative Embedded Microcontroller Architecture

[0177] In some examples, electronics module 70 comprises an embedded-systems microcontroller architecture 800. Power supply 90 and/or input/output hub 80 may be integrated into embedded microcontroller architecture 800. An example embedded microcontroller architecture 800 is depicted schematically in FIG. 20.

[0178] Using embedded microcontroller architecture 800, hyperspectral sensing device 30 is powered by a DC regulator from a power supply such as an internal battery or an auxiliary power supply, which provides stable power output independent of the changes in the electrical load, and can be provided via USB, inductive charging or external power source. The power supply is configured to meet the demand of the on-board sensors, and therefore a DC step-up voltage amplifier can be used to increase the output of a low-voltage battery (such as 3.7V LiPoly/LiIon) to an operating voltage of, for example, 5V. A DC-DC converter can also be used to lower and regulate a higher-voltage DC power supply (for example 12V) to an operating voltage of 5V, or to multiple voltage levels selected for beneficial and/or optimal operation of various sensors and devices. The power is supplied to the micro-controller unit (MCU), sensors, external analog-to-digital converter circuitry as well as input-output (I/O) hub 80.

[0179] Although many micro-controller units feature an integrated multi-channel analog-to-digital converter (ADC), one or multiple external function-specific ADCs may be used to address the needs to process analog signals at high sample rates, in some cases in excess of 1-million samples-per-second (SPS) and/or with increased digital precision, e.g., in the range of 10-bit to 16-bit, or 18-bit, or higher. The analog to digital conversion can be pre-amplified and conditioned using any number of gain-amplification, signal-conditioning, and/or electronics filtering stages, or can be referenced to differential signals to boost the signal while suppressing electronic noise. The digitized video signal from the ADC (from either the hyper-spectral or other analog sensors) are ingested and processed by the MCU and stored in memory, such as a flash memory storage device, e.g., an SD or microSD card, or other memory device for later transfer to an external host computer for additional levels of data processing. The data may additionally be directly up-linked in real-time (while measurements are progressing, or at regularly scheduled intervals) to land-based systems through a wireless or wired device communication port, such as USB, WiFi, Bluetooth, Bluetooth LE, GSM, Iridium, etc.

[0180] The micro-controller (MCU) supplies the operating voltage, clock and trigger timing signals to the sensor 40. The supplied clock rate is used to operate the sensor acquisition and output (video) data rate, while the trigger signal is used to initiate and end the optical integration (or image acquisition), based on the control input from the MCU. The trigger control operation can be programmed via software or firmware and may be adjustable for example based on processing of the camera video output. Additionally, if multiple hyper-spectral sensors are used, the trigger signal may be set to sequentially or synchronously acquire data from multiple sensors.

[0181] In some example triggering schemes, the integration time is determined real-time via software control based on inputs from external signals supplied to the MCU from auxiliary sensors 50. This may for example include temperature, pressure, GPS location, compass heading, tilt/yaw, etc., allowing the sensor to be set to trigger data acquisitions when specific conditions for these parameters are met. For example, the data acquisitions may be set to trigger operating at specific depth intervals or at specific sensor tilt angles. The trigger and clock rates may also be modulated simply to budget the data output rates or manage power consumption during longer operating deployments. Also, the trigger may be activated at specific times in concert with a specific light source 60 or engagement of an optical filter in collector 35 to enable an absorbance, back-scattering or fluorescence measurement.

[0182] In some examples, particularly if data or computational bandwidth limitation exceed the capability of a single MCU, a more powerful micro-processing unit (MPU) or multiple micro-controller units may be used to control and operate driving circuitry for different subsystems, for example for adjustments of the collector aperture, pointing/steering control of the instrument, image stabilization, or fusing of multi-sensor inputs.

K. Illustrative Data Processing System

[0183] As shown in FIG. 21, this example describes a data processing system 900 (also referred to as a computer, computing system, and/or computer system) in accordance with aspects of the present disclosure. Data processing system 900 is an illustrative data processing system suitable for implementing aspects of the hyperspectral sensing systems and devices described above. More specifically, in some examples, devices that are embodiments of data processing systems (e.g., smartphones, tablets, personal computers) may be included on a hyperspectral sensing device (e.g., as part of an on-board electronics module) and used to control acquisition of data by a sensor of the device and/or data communications between the device and a remote server. Additionally, or alternatively, devices that are embodiments of data processing systems may be used to communicate with hyperspectral sensing device(s) to, e.g., program the devices, retrieve data from the devices, etc.

[0184] In this illustrative example, data processing system 900 includes a system bus 902 (also referred to as communications framework). System bus 902 may provide communications between a processor unit 904 (also referred to as a processor or processors), a memory 906, a persistent storage 908, a communications unit 910, an input/output (I/O) unit 912, a codec 930, and/or a display 914. Memory 906, persistent storage 908, communications unit 910, input/

output (I/O) unit 912, display 914, and codec 930 are examples of resources that may be accessible by processor unit 904 via system bus 902.

[0185] Processor unit 904 serves to run instructions that may be loaded into memory 906. Processor unit 904 may comprise a number of processors, a multi-processor core, and/or a particular type of processor or processors (e.g., a central processing unit (CPU), graphics processing unit (GPU), etc.), depending on the particular implementation. Further, processor unit 904 may be implemented using a number of heterogeneous processor systems in which a main processor is present with secondary processors on a single chip. As another illustrative example, processor unit 904 may be a symmetric multi-processor system containing multiple processors of the same type.

[0186] Memory 906 and persistent storage 908 are examples of storage devices 916. A storage device may include any suitable hardware capable of storing information (e.g., digital information), such as data, program code in functional form, and/or other suitable information, either on a temporary basis or a permanent basis.

[0187] Storage devices 916 also may be referred to as computer-readable storage devices or computer-readable media. Memory 906 may include a volatile storage memory 940 and a non-volatile memory 942. In some examples, a basic input/output system (BIOS), containing the basic routines to transfer information between elements within the data processing system 900, such as during start-up, may be stored in non-volatile memory 942. Persistent storage 908 may take various forms, depending on the particular implementation.

[0188] Persistent storage 908 may contain one or more components or devices. For example, persistent storage 908 may include one or more devices such as a magnetic disk drive (also referred to as a hard disk drive or HDD), solid state disk (SSD), floppy disk drive, tape drive, Jaz drive, Zip drive, flash memory card, memory stick, and/or the like, or any combination of these. One or more of these devices may be removable and/or portable, e.g., a removable hard drive. Persistent storage 908 may include one or more storage media separately or in combination with other storage media, including an optical disk drive such as a compact disk ROM device (CD-ROM), CD recordable drive (CD-R Drive), CD rewritable drive (CD-RW Drive), and/or a digital versatile disk ROM drive (DVD-ROM). To facilitate connection of the persistent storage devices 908 to system bus 902, a removable or non-removable interface is typically used, such as interface 928.

[0189] Input/output (I/O) unit 912 allows for input and output of data with other devices that may be connected to data processing system 900 (i.e., input devices and output devices). For example, input device 932 may include one or more pointing and/or information-input devices such as a keyboard, a mouse, a trackball, stylus, touch pad or touch screen, microphone, joystick, game pad, satellite dish, scanner, TV tuner card, digital camera, digital video camera, web camera, and/or the like. These and other input devices may connect to processor unit 904 through system bus 902 via interface port(s) 936. Interface port(s) 936 may include, for example, a serial port, a parallel port, a game port, and/or a universal serial bus (USB).

[0190] Output devices 934 may use some of the same types of ports, and in some cases the same actual ports, as input device(s) 932. For example, a USB port may be used

to provide input to data processing system **900** and to output information from data processing system **900** to an output device **934**. Output adapter **938** is provided to illustrate that there are some output devices **934** (e.g., monitors, speakers, and printers, among others) which require special adapters. Output adapters **938** may include, e.g. video and sounds cards that provide a means of connection between the output device **934** and system bus **902**. Other devices and/or systems of devices may provide both input and output capabilities, such as remote computer(s) **960**. Display **914** may include any suitable human-machine interface or other mechanism configured to display information to a user, e.g., a CRT, LED, or LCD monitor or screen, etc.

[0191] Communications unit **910** refers to any suitable hardware and/or software employed to provide for communications with other data processing systems or devices. While communication unit **910** is shown inside data processing system **900**, it may in some examples be at least partially external to data processing system **900**. Communications unit **910** may include internal and external technologies, e.g., modems (including regular telephone grade modems, cable modems, and DSL modems), ISDN adapters, and/or wired and wireless Ethernet cards, hubs, routers, etc. Data processing system **900** may operate in a networked environment, using logical connections to one or more remote computers **960**. A remote computer(s) **960** may include a personal computer (PC), a server, a router, a network PC, a workstation, a microprocessor-based appliance, a peer device, a smart phone, a tablet, another network node, and/or the like. Remote computer(s) **960** typically include many of the elements described relative to data processing system **900**. Remote computer(s) **960** may be logically connected to data processing system **900** through a network interface **962** which is connected to data processing system **900** via communications unit **910**. Network interface **962** encompasses wired and/or wireless communication networks, such as local-area networks (LAN), wide-area networks (WAN), and cellular networks. LAN technologies may include Fiber Distributed Data Interface (FDDI), Copper Distributed Data Interface (CDDI), Ethernet, Token Ring, and/or the like. WAN technologies include point-to-point links, circuit switching networks (e.g., Integrated Services Digital networks (ISDN) and variations thereon), packet switching networks, and Digital Subscriber Lines (DSL).

[0192] Codec **930** may include an encoder, a decoder, or both, comprising hardware, software, or a combination of hardware and software. Codec **930** may include any suitable device and/or software configured to encode, compress, and/or encrypt a data stream or signal for transmission and storage, and to decode the data stream or signal by decoding, decompressing, and/or decrypting the data stream or signal (e.g., for playback or editing of a video). Although codec **930** is depicted as a separate component, codec **930** may be contained or implemented in memory, e.g., non-volatile memory **942**.

[0193] Non-volatile memory **942** may include read only memory (ROM), programmable ROM (PROM), electrically programmable ROM (EPROM), electrically erasable programmable ROM (EEPROM), flash memory, and/or the like, or any combination of these. Volatile memory **940** may include random access memory (RAM), which may act as external cache memory. RAM may comprise static RAM (SRAM), dynamic RAM (DRAM), synchronous DRAM

(SDRAM), double data rate SDRAM (DDR SDRAM), enhanced SDRAM (ESDRAM), and/or the like, or any combination of these.

[0194] Instructions for the operating system, applications, and/or programs may be located in storage devices **916**, which are in communication with processor unit **904** through system bus **902**. In these illustrative examples, the instructions are in a functional form in persistent storage **908**. These instructions may be loaded into memory **906** for execution by processor unit **904**. Processes of one or more embodiments of the present disclosure may be performed by processor unit **904** using computer-implemented instructions, which may be located in a memory, such as memory **906**.

[0195] These instructions are referred to as program instructions, program code, computer usable program code, or computer-readable program code executed by a processor in processor unit **904**. The program code in the different embodiments may be embodied on different physical or computer-readable storage media, such as memory **906** or persistent storage **908**. Program code **918** may be located in a functional form on computer-readable media **920** that is selectively removable and may be loaded onto or transferred to data processing system **900** for execution by processor unit **904**. Program code **918** and computer-readable media **920** form computer program product **922** in these examples. In one example, computer-readable media **920** may comprise computer-readable storage media **924** or computer-readable signal media **926**.

[0196] Computer-readable storage media **924** may include, for example, an optical or magnetic disk that is inserted or placed into a drive or other device that is part of persistent storage **908** for transfer onto a storage device, such as a hard drive, that is part of persistent storage **908**. Computer-readable storage media **924** also may take the form of a persistent storage, such as a hard drive, a thumb drive, or a flash memory, that is connected to data processing system **900**. In some instances, computer-readable storage media **924** may not be removable from data processing system **900**.

[0197] In these examples, computer-readable storage media **924** is a non-transitory, physical or tangible storage device used to store program code **918** rather than a medium that propagates or transmits program code **918**. Computer-readable storage media **924** is also referred to as a computer-readable tangible storage device or a computer-readable physical storage device. In other words, computer-readable storage media **924** is media that can be touched by a person.

[0198] Alternatively, program code **918** may be transferred to data processing system **900**, e.g., remotely over a network, using computer-readable signal media **926**. Computer-readable signal media **926** may be, for example, a propagated data signal containing program code **918**. For example, computer-readable signal media **926** may be an electromagnetic signal, an optical signal, and/or any other suitable type of signal. These signals may be transmitted over communications links, such as wireless communications links, optical fiber cable, coaxial cable, a wire, and/or any other suitable type of communications link. In other words, the communications link and/or the connection may be physical or wireless in the illustrative examples.

[0199] In some illustrative embodiments, program code **918** may be downloaded over a network to persistent storage **908** from another device or data processing system through

computer-readable signal media **926** for use within data processing system **900**. For instance, program code stored in a computer-readable storage medium in a server data processing system may be downloaded over a network from the server to data processing system **900**. The computer providing program code **918** may be a server computer, a client computer, or some other device capable of storing and transmitting program code **918**.

[0200] In some examples, program code **918** may comprise an operating system (OS) **950**. Operating system **950**, which may be stored on persistent storage **908**, controls and allocates resources of data processing system **900**. One or more applications **952** take advantage of the operating system's management of resources via program modules **954**, and program data **956** stored on storage devices **916**. OS **950** may include any suitable software system configured to manage and expose hardware resources of computer **900** for sharing and use by applications **952**. In some examples, OS **950** provides application programming interfaces (APIs) that facilitate connection of different type of hardware and/or provide applications **952** access to hardware and OS services. In some examples, certain applications **952** may provide further services for use by other applications **952**, e.g., as is the case with so-called "middleware." Aspects of present disclosure may be implemented with respect to various operating systems or combinations of operating systems.

[0201] The different components illustrated for data processing system **900** are not meant to provide architectural limitations to the manner in which different embodiments may be implemented. One or more embodiments of the present disclosure may be implemented in a data processing system that includes fewer components or includes components in addition to and/or in place of those illustrated for computer **900**. Other components shown in FIG. 21 can be varied from the examples depicted. Different embodiments may be implemented using any hardware device or system capable of running program code. As one example, data processing system **900** may include organic components integrated with inorganic components and/or may be comprised entirely of organic components (excluding a human being). For example, a storage device may be comprised of an organic semiconductor.

[0202] In some examples, processor unit **904** may take the form of a hardware unit having hardware circuits that are specifically manufactured or configured for a particular use, or to produce a particular outcome or progress. This type of hardware may perform operations without needing program code **918** to be loaded into a memory from a storage device to be configured to perform the operations. For example, processor unit **904** may be a circuit system, an application specific integrated circuit (ASIC), a programmable logic device, or some other suitable type of hardware configured (e.g., preconfigured or reconfigured) to perform a number of operations. With a programmable logic device, for example, the device is configured to perform the number of operations and may be reconfigured at a later time. Examples of programmable logic devices include, a programmable logic array, a field programmable logic array, a field programmable gate array (FPGA), and other suitable hardware devices. With this type of implementation, executable instructions (e.g., program code **918**) may be implemented as hardware, e.g., by specifying an FPGA configuration

using a hardware description language (HDL) and then using a resulting binary file to (re)configure the FPGA.

[0203] In another example, data processing system **900** may be implemented as an FPGA-based (or in some cases ASIC-based), dedicated-purpose set of state machines (e.g., Finite State Machines (FSM)), which may allow critical tasks to be isolated and run on custom hardware. Whereas a processor such as a CPU can be described as a shared-use, general purpose state machine that executes instructions provided to it, FPGA-based state machine(s) are constructed for a special purpose, and may execute hardware-coded logic without sharing resources. Such systems are often utilized for safety-related and mission-critical tasks.

[0204] In still another illustrative example, processor unit **904** may be implemented using a combination of processors found in computers and hardware units. Processor unit **904** may have a number of hardware units and a number of processors that are configured to run program code **918**. With this depicted example, some of the processes may be implemented in the number of hardware units, while other processes may be implemented in the number of processors.

[0205] In another example, system bus **902** may comprise one or more buses, such as a system bus or an input/output bus. Of course, the bus system may be implemented using any suitable type of architecture that provides for a transfer of data between different components or devices attached to the bus system. System bus **902** may include several types of bus structure(s) including memory bus or memory controller, a peripheral bus or external bus, and/or a local bus using any variety of available bus architectures (e.g., Industrial Standard Architecture (ISA), Micro-Channel Architecture (MSA), Extended ISA (EISA), Intelligent Drive Electronics (IDE), VESA Local Bus (VLB), Peripheral Component Interconnect (PCI), Card Bus, Universal Serial Bus (USB), Advanced Graphics Port (AGP), Personal Computer Memory Card International Association bus (PCMCIA), Firewire (IEEE 1394), and Small Computer Systems Interface (SCSI)).

[0206] Additionally, communications unit **910** may include a number of devices that transmit data, receive data, or both transmit and receive data. Communications unit **910** may be, for example, a modem or a network adapter, two network adapters, or some combination thereof. Further, a memory may be, for example, memory **906**, or a cache, such as that found in an interface and memory controller hub that may be present in system bus **902**.

L. Illustrative Distributed Data Processing System

[0207] As shown in FIG. 22, this example describes a general network data processing system **1000**, interchangeably termed a computer network, a network system, a distributed data processing system, or a distributed network, aspects of which may be used in conjunction with illustrative embodiments of hyperspectral sensing devices and/or systems. For example, hyperspectral sensing devices may transmit acquired data via a network and/or may receive instructions via a network. Network **1000** is an example of a network that may be used for data communication within hyperspectral sensing system **350**.

[0208] It should be appreciated that FIG. 22 is provided as an illustration of one implementation and is not intended to imply any limitation with regard to environments in which different embodiments may be implemented. Many modifications to the depicted environment may be made.

[0209] Network system **1000** is a network of devices (e.g., computers), each of which may be an example of data processing system **900**, and other components. Network data processing system **1000** may include network **1002**, which is a medium configured to provide communications links between various devices and computers connected within network data processing system **1000**. Network **1002** may include connections such as wired or wireless communication links, fiber optic cables, and/or any other suitable medium for transmitting and/or communicating data between network devices, or any combination thereof.

[0210] In the depicted example, a first network device **1004** and a second network device **1006** connect to network **1002**, as do one or more computer-readable memories or storage devices **1008**. Network devices **1004** and **1006** are each examples of data processing system **900**, described above. In the depicted example, devices **1004** and **1006** are shown as server computers, which are in communication with one or more server data store(s) **1022** that may be employed to store information local to server computers **1004** and **1006**, among others. However, network devices may include, without limitation, one or more personal computers, mobile computing devices such as personal digital assistants (PDAs), tablets, and smartphones, handheld gaming devices, wearable devices, tablet computers, routers, switches, voice gates, servers, electronic storage devices, imaging devices, media players, and/or other networked-enabled tools that may perform a mechanical or other function. These network devices may be interconnected through wired, wireless, optical, and other appropriate communication links.

[0211] In addition, client electronic devices **1010** and **1012** and/or a client smart device **1014**, may connect to network **1002**. Each of these devices is an example of data processing system **900**, described above regarding FIG. 21. Client electronic devices **1010**, **1012**, and **1014** may include, for example, one or more personal computers, network computers, and/or mobile computing devices such as personal digital assistants (PDAs), smart phones, handheld gaming devices, wearable devices, and/or tablet computers, and the like. In the depicted example, server **1004** provides information, such as boot files, operating system images, and applications to one or more of client electronic devices **1010**, **1012**, and **1014**. Client electronic devices **1010**, **1012**, and **1014** may be referred to as “clients” in the context of their relationship to a server such as server computer **1004**. Client devices may be in communication with one or more client data store(s) **1020**, which may be employed to store information local to the clients (e.g., cookie(s) and/or associated contextual information). Network data processing system **1000** may include more or fewer servers and/or clients (or no servers or clients), as well as other devices not shown.

[0212] In some examples, first client electric device **1010** may transfer an encoded file to server **1004**. Server **1004** can store the file, decode the file, and/or transmit the file to second client electric device **1012**. In some examples, first client electric device **1010** may transfer an uncompressed file to server **1004** and server **1004** may compress the file. In some examples, server **1004** may encode text, audio, and/or video information, and transmit the information via network **1002** to one or more clients.

[0213] Client smart device **1014** may include any suitable portable electronic device capable of wireless communications and execution of software, such as a smartphone or a

tablet. Generally speaking, the term “smartphone” may describe any suitable portable electronic device configured to perform functions of a computer, typically having a touchscreen interface, Internet access, and an operating system capable of running downloaded applications. In addition to making phone calls (e.g., over a cellular network), smartphones may be capable of sending and receiving emails, texts, and multimedia messages, accessing the Internet, and/or functioning as a web browser. Smart devices (e.g., smartphones) may include features of other known electronic devices, such as a media player, personal digital assistant, digital camera, video camera, and/or global positioning system. Smart devices (e.g., smartphones) may be capable of connecting with other smart devices, computers, or electronic devices wirelessly, such as through near field communications (NFC), BLUETOOTH®, WiFi, or mobile broadband networks. Wireless connectivity may be established among smart devices, smartphones, computers, and/or other devices to form a mobile network where information can be exchanged.

[0214] Data and program code located in system **1000** may be stored in or on a computer-readable storage medium, such as network-connected storage device **1008** and/or a persistent storage **908** of one of the network computers, as described above, and may be downloaded to a data processing system or other device for use. For example, program code may be stored on a computer-readable storage medium on server computer **1004** and downloaded to client **1010** over network **1002**, for use on client **1010**. In some examples, client data store **1020** and server data store **1022** reside on one or more storage devices **1008** and/or **908**.

[0215] Network data processing system **1000** may be implemented as one or more of different types of networks. For example, system **1000** may include an intranet, a local area network (LAN), a wide area network (WAN), or a personal area network (PAN). In some examples, network data processing system **1000** includes the Internet, with network **1002** representing a worldwide collection of networks and gateways that use the transmission control protocol/Internet protocol (TCP/IP) suite of protocols to communicate with one another. At the heart of the Internet is a backbone of high-speed data communication lines between major nodes or host computers. Thousands of commercial, governmental, educational and other computer systems may be utilized to route data and messages. In some examples, network **1002** may be referred to as a “cloud.” In those examples, each server **1004** may be referred to as a cloud computing node, and client electronic devices may be referred to as cloud consumers, or the like. FIG. 22 is intended as an example, and not as an architectural limitation for any illustrative embodiments.

M. Illustrative Data Calibration Methods

[0216] With reference to FIGS. 23-24, this section describes aspects of illustrative data calibration methods for hyperspectral data and/or any other suitable spectral data, in accordance with aspects of the present teachings. In general, data calibration methods described herein allow for processing measured spectral data (e.g., hyperspectral data measured by one or more devices **30**, and/or any other suitable spectral data) to account for environmental and/or instrumental conditions potentially affecting the data. Processing the data in this manner, which may be referred to as calibrating and/or correcting the data, enables a meaningful

comparison between sets of data acquired under conditions known or suspected to be different. Environmental factors such as air temperature, air pressure, humidity, etc. can affect the measurement of data by a hyperspectral and/or multi-spectral sensing device by, e.g., affecting optical refractive indices of components and/or spaces within the device, the rate of production of dark counts in a sensor of the device, etc. Methods of the present teachings process measured data in a manner that controls for these differences. For example, processing two sets of data according to methods of the present teachings allows the two sets of data to be quantitatively compared, even if the two data sets were acquired under different and/or unknown environmental conditions.

[0217] Known methods of data calibration for a spectral sensing device typically require a user to perform certain specialized measurements with the device to obtain calibration data (i.e., data enabling proper calibration of the measured data). For example, some known methods require the device to be removed from the body of water or other location where the device was deployed, so that calibration coefficients can be determined using lab-based measurements. Lab-based measurements are generally difficult to perform in the field (e.g., because they may require carefully controlled conditions, equipment not easily transported, etc.). Accordingly, data calibration methods involving lab-based measurements are inconvenient, time-consuming, and costly to perform, as they require the device to be retrieved from the field and redeployed to the field after obtaining the calibration data. The cost and time involved in obtaining the calibration data can be significant, especially for a network of devices deployed in relatively inconvenient areas, such as a body of water. Accordingly, the lab-based calibration data can practically be acquired relatively infrequently (e.g., seasonally, yearly, etc.) This frequency tends to be inadequate for properly calibrating measured data to account for factors such as temperature and pressure, which can vary significantly throughout a single day.

[0218] Other known methods typically require expensive and/or fragile components to be added to the device, such as an internal light source, a shutter, and/or mechanical steering components enabling the device to orient its input aperture (s) in a specific manner relative to a well-characterized light source such as a reflectance plaque or the moon. These methods increase the complexity and cost of the device, and may not be robust against environmental factors.

[0219] In contrast to known methods, the data calibration methods of the present teachings allow data calibration to be performed using the target data (i.e., the data acquired by the device for its original purpose, such as hyperspectral data acquired for the purpose of water-quality assessment). In other words, the calibration data is the target data, or a subset of the target data. Accordingly, data suitable for use as calibration data is obtained much more frequently than in known methods, and in some cases is obtained continuously. This allows target data to be calibrated using calibration data that was obtained under substantially similar conditions as the target data (e.g., obtained at substantially similar times, viewing angles, and/or environmental conditions). These advantages are enabled by characteristics of the devices of the present teachings (e.g., device **30**), including: hyperspectral sensing capability; ability to function autonomously; size, robustness, and power requirements suitable for deployment in the field; and so on.

[0220] The following subsections describe illustrative examples of data calibration according to the present disclosure.

[0221] a. Illustrative Dark-Current Data Calibration

[0222] In some examples, data calibration includes estimating the contribution of dark current to the measured data, and removing the estimated dark-current contribution from the measured data to produce a set of dark-current-corrected data. The term “dark current” refers to a signal generated in a light-measuring device that corresponds to something other than impinging light. For example, dark current may arise in a CCD, CMOS, or other photosensitive device due to random generation of electrons and/or holes (e.g., in semiconductor components of the device). Because the dark-current signal does not represent information related to light incident on the detector, it is a spurious signal, and the accuracy of the light-related measurement can be improved by removing the dark-current signal from the measured signal.

[0223] The amount of dark current present in data measured by a photosensitive detector (e.g., sensor **40** of hyperspectral sensing device **30**, or any other suitable light detector) typically depends on factors including material properties of the detector, the temperature of the detector, and the integration time of the measurement (i.e., the time interval during which the detector performed a measurement, such as the time during which an electronic and/or mechanical shutter was open). For example, in many cases the dark-current contribution to the signal is expected to be proportional to the integration time of the measurement.

[0224] By definition, the dark-current contribution to the signal is not caused directly by light impinging on the detector. Accordingly, in the presently described method, a measured signal that is known to correspond to a minimal amount of impinging light is attributed substantially or entirely to dark current. The value of that measured signal is therefore treated as an estimation of the spurious signal produced by dark current under the conditions of the measurement (e.g., the temperature and/or other environmental conditions present at the time of the measurement).

[0225] A measured signal corresponding to little or no impinging light (that is, a dark-current estimate) may be obtained in any suitable manner. In some examples, the dark-current estimate is obtained from a spectrum that was measured when light did impinge on the detector. For example, the minimum value of the measured spectrum (e.g., the lowest-value signal in the measured spectral data) may be interpreted as the dark-current estimate. In some cases, however, a low-value signal other than the actual lowest signal may be used (e.g., to avoid a suspected systematic error). Advantageously, the dark-current estimate may be obtained in this manner using a spectrum already measured by the detector rather than a dedicated measurement made specifically for purposes of calibration.

[0226] The dark-current estimate obtained in this manner may be used to calibrate other target data measured under similar conditions, or under any other conditions for which the dark-current estimate is a reasonable approximation to the dark-current contribution to the measured signal. For example, a dark-current estimate obtained using a given integration time may be subtracted from a target spectrum measured using a substantially equal integration time to produce a dark-current-calibrated spectrum.

[0227] In some examples, a plurality of dark-current estimates are obtained for a respective plurality of different integration times (e.g., obtained using target spectra measured at different integration times). This allows for calibrating target spectra measured with those integration times using a dark-current estimate obtained at an equal integration time. The plurality of dark-current estimates and corresponding integration times may further be used to compute projected dark-current estimates for integration times at which no dark-current estimate was measured. For example, data interpolation, machine learning, theoretical models, and/or any other suitable process may be used to obtain computed dark-current estimates based on the measured dark-current estimates.

[0228] In some examples, one or more of the dark-current estimates obtained from a measured spectrum is associated with a temperature corresponding to the measurement, as well as (or instead of) with the measurement integration time. For example, a temperature of the device and/or its environment at the approximate time the spectrum was measured may be recorded and associated with the dark-current estimate. The temperature may be obtained from a temperature sensor on board the device, a temperature sensor disposed near the device, or other temperature data associated with the location where the device was deployed. This allows the dark-current estimate to be used to calibrate spectra that were measured at temperatures substantially identical or similar to that of the spectrum from which the dark-current estimate was derived. Because the device temperature tends to affect the amount of dark current produced, this method may improve the accuracy of the dark-current correction.

[0229] In some examples, the dark-current estimate is subtracted from each point in the spectrum (e.g., from the signal measured at each wavelength and/or each pixel) to produce the dark-current-calibrated spectrum. In other words, the dark-current estimate is treated as a constant offset to the measured spectrum. In other examples, the dark-current estimate is modified in a wavelength-dependent manner, and/or any other suitable manner, prior to subtraction from the measured spectrum.

[0230] FIG. 23 is a flowchart depicting steps performed in an illustrative method 1200 for obtaining dark-current-corrected spectral data. Aspects of hyperspectral sensing systems and devices described above (e.g., device 30) may be utilized in the method steps described below. Where appropriate, reference may be made to components and systems that may be used in carrying out each step. These references are for illustration, and are not intended to limit the possible ways of carrying out any particular step of the method.

[0231] FIG. 23 is a flowchart illustrating steps performed in an illustrative method, and may not recite the complete process or all steps of the method. Although various steps of method 1200 are described below and depicted in FIG. 23, the steps need not necessarily all be performed, and in some cases may be performed simultaneously or in a different order than the order shown.

[0232] At step 1202, method 1200 includes obtaining a plurality of measured spectra. In some examples, the measured spectra comprise hyperspectral measurements obtained using a hyperspectral sensing device (e.g., device 30) deployed in a remote location (e.g., on, in, or adjacent a body of water). As described above, a hyperspectral

spectrum includes a quantitative representation of a signal measured at each of a plurality of narrow, adjacent spectral bands spanning a suitable wavelength range (e.g., some or all of the visible, ultraviolet, and/or infrared spectrum ranges). The signal at each spectral value includes a light level of any light having the corresponding wavelength and impinging on the detector, as well as the spurious dark-current signal, as described above. Quantitatively, the measured signal may comprise a number of counts, an electric field strength, a power, and/or an intensity represented in any suitable units. Suitable units may include physical units, such as a power or energy per unit area, one or more digital numbers associated with photodetector bits involved in the measurement, and/or arbitrary units.

[0233] The plurality of measured spectra include spectra measured with at least two respective different integration times (e.g., two, five, ten, or more different integration times) within a suitable range of integration times (e.g., 0 to 3 seconds, 150 microseconds to 2 seconds, and/or any other suitable range). Some of the spectra may have been measured using the same integration time (i.e., there may be more than one measured spectrum for some or all of the plurality of integration times).

[0234] In some examples, the plurality of measured spectra are transmitted from the device (e.g., wirelessly) to a receiver that is remote from the device (e.g., a receiver disposed at a distance of several feet, tens of feet, hundreds of feet, thousands of feet, or miles away from the device). Alternatively, or additionally, the measured spectra may be offloaded from a memory store of the device using a wired connection. For example, the measured spectral data may be transferred from the device to a computer or storage device, either in the field (e.g., without removing the device from its remote deployment location) or in a different location (e.g., after retrieving the device).

[0235] At step 1204, method 1200 optionally includes identifying a subset of the measured spectra corresponding to certain measurement conditions. In some examples, the subset of measured spectra is selected based on known or suspected atmospheric and/or environmental conditions at the time of the measurement. For example, certain atmospheric conditions, such as low glint, lack of cloud cover, and/or lack of atmospheric contaminants such as water and ozone, tend to be more accurately modeled by known simulations of the atmosphere. Because atmospheric simulations may be used in conjunction with the acquired data (e.g., for further data calibration, for water-quality assessment, etc.), it may be advantageous to obtain dark-current estimates from measured spectra corresponding to conditions that allow accurate simulation. Additionally, or alternatively, spectra acquired under these conditions may enable a more accurate and/or precise dark-current estimate than spectra acquired under some other conditions (e.g., conditions corresponding to high glint and/or a high concentration of atmospheric contaminants). Accordingly, a subset of spectra corresponding to these conditions may be identified by consulting data relating to atmospheric and/or weather conditions at the day and time at which the spectra were measured, and selecting spectra measured at times when conditions were preferable.

[0236] In some examples, data relating to environmental conditions may be obtained from the device itself. For example, data obtained from auxiliary sensors on the device such as humidity sensors, ozone sensors, and so on may be

used to identify preferable environmental conditions. In some examples, the intensity of light measured by the photosensitive detector of the device (e.g., an intensity in one of the measured spectra) may be used to estimate cloud cover and thus to identify sunny days. Alternatively, or additionally, the data relating to environmental conditions may be obtained from sensors not associated with the device, from an external database (e.g., from a weather service, research station, etc.), and/or from any other suitable source.

[0237] Alternatively, or additionally, a subset of the measured spectra may be selected on another suitable basis. In other examples, no subset is selected, and all of the obtained measured spectra are used in subsequent method steps.

[0238] At step 1206, method 1200 includes determining, for each of the plurality of measured spectra (or for each spectrum in the subset identified at step 1204, if applicable), a lowest value of the measured signal. As described above, the lowest value of the measured signal comprises an estimate of the dark-current contribution to the signal at each part of the spectrum. Accordingly, step 1206 produces an estimated dark-current contribution for each measured spectrum. The dark-current estimate is associated with the integration time corresponding to the measured spectrum.

[0239] As an example, suppose the minimum signal of a spectrum measured using an integration time of 500 microseconds occurs at 480 nanometers (nm) and has a value of 0.05 arbitrary units. In this case, the signal corresponding to 480 nm is identified as the lowest measured value at step 1206, and 0.05 arbitrary units is interpreted as an estimate of the dark-current contribution to the signal at all wavelengths. Furthermore, as described above, the estimated dark-current contribution of 0.05 may be used as an estimate of the dark-current contribution to other spectra measured with an integration time equal to or nearly equal to 500 microseconds.

[0240] In some examples, the lowest value of the signal of each spectrum is selected at step 1206 irrespective of the wavelength at which the lowest value is found. Alternatively, in some examples the lowest value within a certain subset of the available spectrum is identified at step 1206. This may be the case if, for example, a device malfunction or other problem is suspected at certain wavelengths.

[0241] Accordingly, step 1206 produces a plurality of dark-current estimates, each estimate being associated with the integration time of the measured spectrum from which the estimate was obtained. The dark-current estimates and associated integration times may be represented as ordered pairs of data.

[0242] At step 1208, method 1200 includes using the dark-current estimates obtained at step 1206 to compute a projected dark-current estimate corresponding to a selected integration time. For example, the dark-current estimates obtained directly from the measured spectra at step 1206 may be used to obtain a computed dark-current estimate corresponding to an integration time for which no measured spectrum was present at step 1206. In some examples, obtaining one or more computed dark-current estimates based on the direct estimates from step 1206 includes fitting a function to the data obtained at step 1206 (e.g., using polynomial interpolation, spline interpolation, regression, and/or the like) and using the function to predict a dark-current estimate at a selected integration time. In some examples, obtaining the computed dark-current estimate(s)

is performed at least in part by one or more neural networks, support vector machines, and/or any other suitable machine learning and/or artificial intelligence.

[0243] At step 1210, method 1200 includes correcting a first measured spectrum for dark current by subtracting from the first measured spectrum a first dark-current estimate. The first dark-current estimate corresponds to the integration time associated with the first measured spectrum, and may also correspond to a temperature or other environmental characteristic associated with the time at which the first spectrum was measured. Subtracting the first dark-current estimate from the first measured spectrum in this example includes subtracting the first dark-current estimate from every value in the first measured spectrum (e.g., from the signal at every wavelength and/or every pixel in the first measured spectrum). Put another way, the entire first measured spectrum is offset by the first dark-current estimate. A measured spectrum that has been offset in this manner may be referred to as a dark-current-calibrated spectrum and/or a dark-current-corrected spectrum.

[0244] In some examples, the first measured spectrum that is dark-current-calibrated at step 1210 is one of the plurality of measured spectra received at step 1202. In this case, the first dark-current estimate may be one of the dark-current estimates directly obtained at step 1206 (e.g., the lowest value of the first measured spectrum), or it may be a computed dark-current estimate obtained at step 1208. In other examples, the first measured spectrum is not one of the plurality of measured spectra received at step 1202, and the first dark-current estimate is a computed dark-current estimate derived at step 1208.

[0245] The dark-current-calibrated spectrum obtained at step 1210 may be used in any suitable manner. For example, the dark-current-calibrated spectrum may be analyzed to determine quantities relevant to water-quality assessment, such as chlorophyll concentrations. Additionally, or alternatively, the dark-current-calibrated spectrum may be used to update, calibrate, and/or confirm remote-sensing data obtained by a satellite or other airborne device from the location where the device was deployed. Optionally, prior to being used for these or any other suitable purposes, the dark-current-calibrated spectrum may be calibrated for one or more additional factors, as described below.

[0246] b. Illustrative Radiometric Calibration

[0247] In some examples, data calibration in accordance with aspects of the present teachings includes radiometric data calibration, AKA radiance or irradiance calibration. Radiometric data calibration allows for correcting measured spectra to account for factors affecting the measurement of light by the sensor that are not directly related to the properties intended to be observed. For example, consider a hyperspectral sensor deployed adjacent a body of water for the purpose of measuring spectra of light propagating from the water's surface, which can be used for water quality assessment. Light entering the sensor from the water's surface typically has traveled through the atmosphere to the water prior to being scattered or otherwise directed upward back through the water's surface. Accordingly, at least some properties of the light are at least partly determined by effects arising from the transfer of light through the atmosphere (e.g., scattering, absorption, etc.), solar elevation or angle, and/or other effects not directly related to the water-related characteristic being assessed. Radiometric calibration tends to correct for these effects, facilitating the com-

parison of data measured at different times, different geographic locations, and/or by different sensors.

[0248] In general, radiometric data calibration of a measured spectrum in accordance with aspects of the present teachings involves a comparison between the measured spectrum and a simulated spectrum (or spectrum portion). The simulated spectrum or spectral data is calculated based on model(s) accounting for atmospheric effects on the measured light, and/or any other suitable effects. The simulation is adjusted (e.g., by varying one or more simulation parameters such as atmospheric aerosol concentration, relative humidity, etc.) to substantially match the measured spectrum according to one or more predefined criteria. For example, a nonlinear optimization may be performed such that the difference between the measured and simulated spectra is substantially minimized. Adjusting the simulation such that the simulation predicts spectral data consistent with the measured data tends to make the simulation accurately represent the atmospheric and/or surface conditions of the measurement. Accordingly, the adjusted simulation is used to calibrate the measured spectrum to account for atmospheric effects.

[0249] Calibrating the measured spectrum generally includes obtaining a mathematical transformation between the measured spectrum and the simulated spectrum produced by the adjusted simulation. Because it is based on the simulated spectrum corresponding to the adjusted parameters, this transformation inherently tends to account for atmospheric, surface, and/or environmental effects (e.g., solar azimuth, solar elevation, etc.). Suitable mathematical transformations may include linear or nonlinear regressions, ratios, convolutions, and/or arithmetic differences. Applying the obtained mathematical transformation to the measured spectrum produces a radiometrically calibrated spectrum. For example, the measured spectrum may be regressed against a simulated spectrum produced by the adjusted simulation to produce a radiometrically calibrated spectrum. In some examples, the mathematical transformation may additionally or alternatively be applied to a second measured spectrum (e.g., a spectrum measured under similar environmental and/or atmospheric conditions as the measured spectrum on which the transformation is based) to radiometrically calibrate the second measured spectrum.

[0250] A radiometrically calibrated spectrum may be analyzed for water-quality assessment purposes and/or any other suitable purpose(s) without confounding atmospheric effects. Additionally, or alternatively, a calibrated spectrum may be meaningfully compared to another calibrated spectrum obtained under different conditions (e.g., at a different time and/or place, with a different sensor, etc.).

[0251] FIG. 24 is a flowchart depicting steps performed in an illustrative method 1300 of obtaining radiometrically corrected spectral data. Aspects of hyperspectral sensing systems and devices described above (e.g., device 30) may be utilized in the method steps described below. Where appropriate, reference may be made to components and systems that may be used in carrying out each step. These references are for illustration, and are not intended to limit the possible ways of carrying out any particular step of the method.

[0252] FIG. 24 is a flowchart illustrating steps performed in an illustrative method, and may not recite the complete process or all steps of the method. Although various steps of method 1300 are described below and depicted in FIG. 24,

the steps need not necessarily all be performed, and in some cases may be performed simultaneously or in a different order than the order shown.

[0253] At step 1302, method 1300 includes obtaining data representing a spectrum measured by a photosensitive device (e.g., a hyperspectral sensing device such as device 30, and/or any other suitable device). For example, the spectrum may be a spectrum of downwelling solar irradiance, upwelling radiance from a water body, and/or any other suitable spectrum. The spectrum may comprise hyperspectral data, multispectral data, and/or any other suitable spectral data. The measured spectrum may be obtained directly or indirectly from the device.

[0254] In some examples, the obtained spectrum was measured under environmental and/or atmospheric conditions that enable especially accurate modeling. For example, the spectrum may have been measured on a clear sunny day with relatively small amounts of atmospheric contaminants. At least some known methods of simulating the behavior of light in the atmosphere tend to be most accurate under these conditions. However, a spectrum measured under any suitable conditions may be used.

[0255] At step 1304, method 1300 optionally includes calibrating the measured spectrum for dark current, as described above with reference to method 1200. Step 1304 may be omitted if, e.g., the dark-current calibration was performed prior to obtaining the measured spectrum at step 1302, or if the dark-current calibration is unnecessary or undesired for some other reason.

[0256] At step 1306, method 1300 optionally includes performing a near-infrared correction on the measured spectrum. A near-infrared correction may be performed in cases where it is known or suspected that absorption of near-infrared light by water strongly affects the measured spectrum. Liquid water tends to very strongly absorb light having near-infrared wavelengths and/or mid-infrared wavelengths (e.g., light having wavelengths approximately within a range of 700 nm to 3000 nm). Accordingly, if the measured spectrum corresponds to light that passed through a significant amount of water (e.g., if the spectrum corresponds to upwelling radiance from a clear body of water with little bottom reflectance), it can be inferred that the true upwelling radiance includes very little or no light in the mid-infrared range, and that some or all signals actually measured by the sensor in this wavelength range are likely spurious (e.g., they likely correspond to light other than upwelling light from the desired angle).

[0257] Accordingly, at least a portion of the signal measured in the near-infrared or mid-infrared (for example, the lowest signal value measured in that wavelength range) may be attributed substantially entirely to spurious sources and subtracted from the signal values in that portion of the spectrum to improve the accuracy of the measurement. Specifically, in example step 1306, the lowest value in the measured spectrum within the range 700-750 nm is subtracted from all of the values within that range. This step comprises a near-infrared correction to the measured spectrum. The exact wavelength range used may be modified based on properties of the water, the sensor, and/or any other suitable properties.

[0258] Step 1306 may be omitted if it is unneeded or undesirable (e.g., in a situation where the correction is believed to be inaccurate, such as situations in which it is

unlikely that water absorption significantly attenuated the near-infrared portion of the spectrum).

[0259] At step **1308**, method **1300** includes normalizing the measured spectrum (typically after any applicable correction at steps **1304** or **1306**). Normalizing the measured spectrum includes rescaling the values of the measured signal (e.g., by multiplying the measured value at each wavelength by a normalizing factor). This enables sensible comparison between spectra measured at different levels of solar illumination. In some examples, the measured spectrum is normalized to the largest signal value measured. In some examples, the measured spectrum is normalized to the largest signal value measured between approximately 450 nm and 650 nm, which is the brightest wavelength range in many use cases.

[0260] At step **1310**, method **1300** includes simulating one or more wavelength-dependent radiance or irradiance values (e.g., a spectrum, or one or more portions of a spectrum) expected to be measured by an ideal sensor (e.g., in the absence of nuisance signal, sensor imperfections, and/or other effects described above). In some examples, the simulated spectrum has a wavelength range identical or approximately equal to a wavelength range of the measured spectrum. In other examples, the simulated spectrum has a wavelength range smaller than the wavelength range of the measured spectrum (e.g., corresponding to one or more adjacent and/or non-adjacent portions of the wavelength range of the measured spectrum).

[0261] The simulation may be based on known characteristics of the solar spectrum at the top of the atmosphere (e.g., before passing through the atmosphere), physical and/or chemical models of the atmosphere and the passage of light through the atmosphere, and/or any other suitable information. For example, the simulation may comprise an atmospheric radiative transfer function. The simulation may additionally or alternatively include solar and sensor viewing geometries corresponding to the measurement of the measured spectrum.

[0262] The simulation includes at least one adjustable parameter. Suitable adjustable parameters may include characteristics of the atmosphere (e.g., aerosol concentrations, water vapor concentrations, and/or the like), and/or any other suitable factors expected to affect light transfer through the atmosphere.

[0263] In some examples, the simulation is based in whole or in part on known models such as the commonly used computer-based models MODTRAN®, 6S or 6SV, and/or any other models. Additionally, or alternatively, models based on machine learning or other forms of artificial intelligence may be used.

[0264] In some examples, some or all of the adjustable simulation parameters correspond directly to physical properties of the atmosphere, such as concentrations of certain molecules. Additionally, or alternatively, some or all of the adjustable parameters may comprise model parameters (e.g., weighting factors) that do not directly correspond to a specific physical property.

[0265] In some examples, the simulation of step **1310** includes models known to be most accurate in clear weather with minimal atmospheric contaminants. For this reason, the spectrum obtained at step **1302** is in some examples measured under these conditions. Additionally, or alternatively, the spectrum may have been measured at or near one or more desired solar angles and/or sensor viewing angles. For

example, the spectrum may have been measured at solar zenith. This avoids the need for a cosine approximation in certain calculations, reducing computational complexity and error. In some examples, the spectrum is measured with the sun positioned substantially at (90°, 40°) polar and azimuthal angles, which may tend to minimize the contribution of sky reflectance to the spectrum. This may enable a more accurate measurement of water-leaving radiance (e.g., in examples where the spectrum corresponds to upwelling light from a surface of a body of water). However, any suitable spectrum may be used.

[0266] Initial values of the adjustable simulation parameters may be selected in any suitable manner. For example, one or more parameters may be selected to approximately fit the simulated values to one or more benchmark features of the measured spectrum. (As described below, a better fit is typically achieved at step **1312**.) Additionally, or alternatively, the initial values of the parameters may be chosen randomly, arbitrarily, and/or by any other suitable method.

[0267] Suitable benchmark features may include, e.g., Fraunhofer lines of the solar spectrum, absorption lines of O₂, H₂O, and/or the like. A suitable benchmark feature may be selected based on characteristics of the measured spectrum. For example, if the spectrum corresponds to upwelling radiance from a body of water, and the spectrum was measured with a device disposed relatively near the water's surface (e.g., within ten meters of the surface), then the O₂-A absorption band may be a suitable benchmark, because the amount of light that could have been absorbed by O₂ between the water's surface and the sensor is negligible. If, on the other hand, the spectrum was measured by a sensor disposed at a greater distance above the surface, then a non-negligible amount of light leaving the surface may have been absorbed by the atmosphere before reaching the sensor. In this case, the simulated values of radiance or irradiance near the O₂ band are not expected to match the measured spectrum, so a different benchmark is selected.

[0268] In some examples, one or more initial values or seed values for the simulations are obtained based on a depth of a benchmark absorption line. For example, the method may include identifying a first signal value at a first side of the line, a second signal values at a second side of the line, and a third value within the absorption line. A difference between the first and third value and a difference between the second and third value is obtained. These differences are related to the absorption depth of the benchmark line. An estimated optical thickness of key atmospheric components is obtained based on the differences. For example, if the benchmark is an O₂ absorption line, the optical thickness of O₂ in the atmosphere is obtained. The optical thickness may be calculated based on a model of propagation of light through the atmosphere. For example, the optical thickness may be calculated as a decay constant in a model based on exponential decay (e.g., Beer's Law). The calculated optical thickness, and/or one or more atmospheric characteristics derived therefrom, may be used as an initial parameter value for the simulation. An initial value obtained in this manner tends to be relatively close to the value ultimately obtained through iterative adjustment (see below), which helps any fitting and/or optimization methods involved in the adjustment to converge.

[0269] At step **1312**, method **1300** includes iteratively adjusting one or more simulation parameters such that the simulated values fit the one or more benchmark features of

the measured spectrum according to one or more predefined criteria (e.g., within one or more predefined tolerances). Iteratively adjusting the simulation parameters to fit the simulated values to the measured spectrum may include, e.g., interpolating the simulated values across the benchmark line, fitting one or more other radiance (or irradiance) values to the measured spectrum simultaneously, nonlinear optimization, and/or any other suitable adjustment. Any suitable fitting procedure may be used. In some examples, parameters are iterated until the respective simulated values of one or more benchmark absorption lines are below predefined threshold(s) (e.g., absorption depths).

[0270] At step 1314, method 1300 optionally includes accounting for a sensor response function associated with the measuring device. In general, a sensor response function quantitatively characterizes the signal produced by the sensor in response to a given input. An ideal sensor would produce a signal that exactly reproduces the input, but a real physical sensor produces a signal that inevitably deviates at least slightly from the input. The deviations may be due to factors such as loss and dispersion within the photosensor and associated optics, limited resolution or sensitivity of the detector, and/or the like. Mathematically, the signal produced by the sensor comprises a convolution of the input with the sensor response function. If the sensor response function of the device that measured the spectrum obtained at step 1302 is known or may be reasonably approximated, it may be accounted for at optional step 1314. For example, a simulated spectrum or portion of a spectrum produced by the adjusted simulation may be convolved with the sensor function to produce an even more accurate prediction of the measured spectrum. Alternatively, or additionally, the measured spectrum and the sensor response function may be deconvolved, producing a modified version of the measured spectrum that accounts for instrumental effects. This enables a better comparison to the simulation.

[0271] At step 1316, method 1300 includes obtaining a mathematical transformation between the simulated and measured spectra, and transforming the measured spectrum using the transformation to produce a radiometrically calibrated spectrum. For example, step 1316 may include linearly regressing the measured spectrum to produce a calibrated measurement. The mathematical transformation may additionally or alternatively be used to transform another measured spectrum into a calibrated spectrum.

[0272] Methods 1200 and 1300 may be performed using any suitable device. However, using one or both of these methods to calibrate data obtained using hyperspectral sensing device 30, described above, may be especially advantageous. As described above, device 30 is configured to be deployed in a remote location (e.g., on a body of water) and to collect data substantially continuously under a wide range of illumination conditions and in a wide range of environmental conditions. For example, the device has a small size, low power requirements, few or no moving mechanical parts, short data sampling intervals, autonomous functioning capability, adjustable integration time (which effectively amounts to a dynamic gain), the ability to change operating parameters based on sensed conditions, and so on. Because the device can continuously measure spectra even in difficult conditions, and because the methods of the present disclosure include using the measured spectra to perform calibrations, data suitable for use in calibration is continuously

produced and is available for many different environmental conditions. No known device, system, or method has these advantages.

N. Illustrative Method for Measuring Water-Leaving Radiance

[0273] With reference to FIG. 25, this section describes an illustrative method of measuring water-leaving radiance (e.g., for the purpose of calculating a remote-sensing reflectance, or for any other suitable assessment). As described above, water-leaving light comprises light emerging from beneath the surface of a body of water (e.g., light from the sky that traveled beneath the surface and was eventually scattered or otherwise emitted upward through the surface), and by definition does not include light that was reflected directly from the surface of the water substantially without traveling underwater. Measuring water-leaving radiance typically includes detecting a total upwelling light (comprising, e.g., the water-leaving light together with any surface-reflected light and/or any light scattered from the atmosphere into the detector without reaching the water at all), and correcting the measured upwelling light spectrum to obtain a spectrum corresponding to substantially only the water-leaving light. Aspects of methods of correcting the upwelling light measurement are discussed above in Section D. Another method of correcting an upwelling light measurement by iteratively adjusting a simulation is described below.

[0274] FIG. 25 is a flowchart depicting steps performed in an illustrative method 1400 of obtaining an accurate measurement of water-leaving radiance. Aspects of hyperspectral sensing systems and devices described above (e.g., device 30) may be utilized in the method steps described below. Where appropriate, reference may be made to components and systems that may be used in carrying out each step. These references are for illustration, and are not intended to limit the possible ways of carrying out any particular step of the method.

[0275] FIG. 25 is a flowchart illustrating steps performed in an illustrative method, and may not recite the complete process or all steps of the method. Although various steps of method 1400 are described below and depicted in FIG. 25, the steps need not necessarily all be performed, and in some cases may be performed simultaneously or in a different order than the order shown.

[0276] At step 1402, method 1400 includes obtaining a measured spectrum of upwelling light above a surface of a body of water. In some examples, the spectrum is measured by hyperspectral sensor 30 based on light received at a water-directed aperture of the sensor, the aperture being positioned at a relatively small distance above the surface of the water. However, in other examples, the spectrum may be obtained in any other suitable way. For example, the upwelling light may be measured at a greater distance above the water, and/or with a different type of instrument. Obtaining the spectrum may include measuring the spectrum and/or receiving the measured spectrum directly or indirectly from the measurement device.

[0277] At step 1404, method 1400 optionally includes obtaining a measured spectrum of downwelling light above the surface of the water. In some examples, the spectrum is measured by device 30 (e.g., based on light received at a sky-directed aperture of the sensor). However, in other examples, the spectrum may be obtained in any other

suitable way. The measured downwelling spectrum and the measured upwelling spectrum may or may not be measured using the same device.

[0278] In some examples, only the upwelling light spectrum is obtained. That is, step 1404 may be omitted. However, it is common to obtain both the downwelling and upwelling spectra to facilitate calculating a quantity that depends on both the downwelling and upwelling light. An example of such a quantity is the remote-sensing reflectance, discussed in Section D.

[0279] At step 1406, method 1400 includes simulating at least a portion of an upwelling light spectrum using a simulation having at least one adjustable parameter. In examples wherein step 1404 was performed, a downwelling spectrum or spectrum portion may additionally (or alternatively) be obtained from the simulation. The simulated spectrum values represent a theoretical and/or computational prediction of the spectrum of downwelling (or upwelling) light above the surface of the body of water.

[0280] At step 1406, the simulation may or may not include parameters, models, or other aspects that are specifically configured to represent the conditions under which the spectra obtained at steps 1402 and 1404 were measured. For example, the simulation may include values of temperature, pressure, solar angle, and/or other parameter(s) corresponding to the time and place the spectra were measured, or they may include estimated, standard, and/or arbitrary values. As discussed below, at step 1408, the simulation parameters are adjusted.

[0281] Simulating the spectrum or spectrum portion(s) at step 1406 may include, e.g., running a computer-implemented simulation based on one or more aspects of the atmosphere and/or the body of water. For example, step 1406 may include establishing an atmospheric transfer function modeling the propagation of light through one or more layers of the atmosphere. The atmospheric transfer function may predict light transfer through any suitable portions of the atmosphere and/or substantially all layers of the atmosphere (e.g., from the top of the atmosphere to the surface of the body of water). Performing the simulation may include using MODTRAN®, 6S or 6SV, and/or any suitable model(s).

[0282] Simulating the spectral values at step 1406 may additionally or alternatively include simulating an interaction of light with the surface (and/or near-surface portions) of the body of water. For example, step 1406 may include establishing a bidirectional reflectance distribution function, as described above in Section D.

[0283] In general, any suitable model or (combination of models) having at least one adjustable parameter may be used at step 1406 to obtain the simulated spectra or spectrum portion(s). Adjustable parameters may include characteristics of the atmosphere (e.g., aerosol concentrations, water vapor concentrations, and/or the like), and/or any other suitable factors. Initial values of the adjustable parameters may be selected using any suitable method(s), and may reflect the conditions of the measurement to any extent.

[0284] At step 1408, the method includes iteratively adjusting the simulation by adjusting one or more adjustable simulation parameters such that the simulated spectra (or spectra portions) match the measured spectra according to one or more predefined criteria. For example, simulated parameters may be adjusted until one or more benchmark features of the simulated spectra are fit to the corresponding

benchmark feature in the measured upwelling or downwelling spectra. Suitable benchmark features may include absorption lines corresponding to Fraunhofer solar lines, O₂ absorption lines, H₂O absorption lines, and/or any other spectral features expected to be present and recognizable in the measured and simulated spectra. The simulation may be iterated until the simulated benchmark and the measured benchmark agree within a predetermined tolerance.

[0285] The adjusted simulation, including the adjusted parameters that result in a fit between the simulated and measured spectra, is taken to be an accurate simulation of the atmosphere and/or body of water at the time of the measurement.

[0286] At step 1410, the method includes determining an accurate spectrum of the water-leaving radiance by correcting the measured upwelling spectrum based on the adjusted simulation. Correcting the measured upwelling spectrum includes using the adjusted simulation to predict the contribution to the measured upwelling spectrum by light other than water-leaving light. For example, if the upwelling spectrum was measured by a detector positioned close to the water's surface, correcting the measured spectrum includes using the adjusted simulation to predict the spectrum of the surface-reflected light, and subtracting the predicted spectrum from the measured spectrum to obtain a corrected measured spectrum that accurately represents the spectrum of water-leaving light.

[0287] In examples wherein path radiance (e.g., light that reaches the detector without having interacted with the water's surface) is expected to be non-negligible, correcting the measured spectrum additionally or alternatively includes using the adjusted simulation to predict the path-radiance spectrum, and subtracting the path-radiance spectrum from the measured upwelling spectrum. In general, any suitable corrections involving an accurate simulation of the atmosphere and/or body of water may be performed at step 1410.

[0288] A corrected measured spectrum obtained by a simulation adjusted in this manner may be used for any suitable purpose. For example, a corrected measured spectrum of water-leaving radiance may be used to calculate a remote-sensing reflectance. Alternatively, or additionally, a corrected measured spectrum may be used as a basis for estimating a spectrum corresponding to another location. For example, a corrected measured spectrum may be used as "ground-truth" data to update data obtained from an airborne device scanning a body of water where no near-surface devices have been deployed.

[0289] In some examples, method 1400 is performed in conjunction with method 1200 and/or method 1300. In other words, the measured spectrum that is corrected by method 1400 may be further adjusted to account for dark-current contributions and/or radiometric calibration factors. In some examples, simulation(s) used for method 1300 may also be used for method 1400. Method 1400 may be referred to as an atmospheric correction and/or a preprocessing step.

[0290] As described above with reference to methods 1200 and 1300, method 1400 may be performed using spectra acquired by any suitable measurement device. However, using hyperspectral sensing device 30, may be especially advantageous due to, e.g., the ability of the device to continuously measure spectra even in difficult conditions.

O. Illustrative Functional-Basis Representation of Hyperspectral Data

[0291] This section describes illustrative methods involving representations of spectral data in a functional basis, in accordance with aspects of the present teachings. In general, representing spectral data in a functional basis space includes selecting a suitable functional basis for the representation and determining, for each data set to be represented, a function representing the respective data set in the selected basis. Determining the representative function typically includes determining values for one or more weighting coefficients and/or other parameters, at least some of which may be basis-dependent. A representative function may also be referred to as an approximating function.

[0292] A functional basis space comprises a set of basis functions defining a basis space, wherein any suitable function existing within the space is representable by a linear combination of basis functions. (Suitable functions for representation within the basis space may include functions meeting one or more mathematical requirements, such as being continuous and/or differentiable.) This is analogous in at least some respects to a vector space defined by basis vectors, wherein each vector in the space can be represented by a linear combination of basis vectors.

[0293] Suitable examples of functional basis spaces include basis spaces defined by polynomial basis functions, spline basis functions, wavelet basis functions, radial basis functions, and/or any other suitable bases. A functional basis space may be defined by any suitable number of functions, including an infinite number of functions.

[0294] As described above, a spectrum measured by a wavelength-sensitive photodetector (e.g., a spectrometer of device 30) comprises a set of data including, for each spectral band in the spectrum, a quantitative measure of the associated light level (e.g., intensity, digital number, and/or the like). In accordance with aspects of the present teachings, the measured spectrum is represented as a linear combination of basis functions, wherein the basis functions and the linear combination thereof are generally functions of wavelength. Additional data processing techniques such as derivative, difference, and/or other variational analysis methods may optionally be performed on the functional-basis representation of the spectrum to increase a signal-to-noise ratio, identify features of the data, and/or to otherwise process and/or analyze the data.

[0295] The functional basis representation of measured spectra in accordance with aspects of the present teachings enables several advantages over known methods of representing and/or using measured spectra. For example, the functional basis representation is typically more computationally efficient than a raw data set. In cases wherein the measured spectrum is hyperspectral, the spectrum may include hundreds or thousands (or more) of spectral bands, so a data set representing the spectrum may become large and unwieldy. A representative functional-basis function that maps any wavelength in the domain to the corresponding light level is a more efficient way of representing the spectral data. Additionally, the function may be implementable in a computer system in a manner that is better suited for certain purposes (e.g., use in an object-oriented software program) than is a data set.

[0296] Another advantage of a functional-basis representation compared to a data set is that known methods of using a data set (e.g., for purposes of water-quality assessment)

typically rely on only a subset of the spectral bands in the spectrum. In other words, not all of the data is used in known methods, so any assessment made based on the data set effectively ignores at least some of the information contained in the spectrum. For example, known methods of computing quantities such as chlorophyll concentration use intensities measured at several discrete wavelengths, and discard the rest of the measured spectrum.

[0297] In contrast, the functional-basis representation of the spectrum is determined using all of the measured spectral data, and the entirety of the information contained in the spectrum is necessarily included. Accordingly, the functional-basis representation of the spectrum incorporates aspects of the data, such as subtle patterns or small features, that are typically lost when using known methods. This makes the functional-basis representation of the spectrum advantageous for applications wherein computations are performed based on the spectrum. Such applications may include computing water transparency, turbidity, temperature; concentrations and/or amounts of sediment, chlorophyll, colored dissolved organic matter, nitrogen, phosphorous, particulates, and/or any other suitable quantity.

[0298] Another example application is using spectral data acquired by a near-surface sensor (i.e., ground-truth data) to update spectral data acquired by a remote sensor (e.g., a satellite) from a location where no suitable corresponding ground-truth data is available. FIG. 26 is a flowchart depicting steps performed in an illustrative method 1500 of updating remote data using respective functional-basis representations of another set of remote data and corresponding ground-truth data. Aspects of hyperspectral sensing systems and devices described above (e.g., device 30) may be utilized in the method steps described below. Where appropriate, reference may be made to components and systems that may be used in carrying out each step. These references are for illustration, and are not intended to limit the possible ways of carrying out any particular step of the method.

[0299] FIG. 26 is a flowchart illustrating steps performed in an illustrative method, and may not recite the complete process or all steps of the method. Although various steps of method 1500 are described below and depicted in FIG. 26, the steps need not necessarily all be performed, and in some cases may be performed simultaneously or in a different order than the order shown.

[0300] At step 1502, method 1500 includes acquiring a ground-truth spectrum corresponding to a first location. In some examples, the ground-truth spectrum is measured using a hyperspectral sensor, such as device 30, deployed at the first location. However, any suitable spectrum may be used.

[0301] The sensor that measures the ground-truth spectrum is disposed near the surface of the location being measured. For example, it may be disposed near the surface of a body of water, near the ground, and/or near the top of a tree canopy. The spectrum may correspond to an upwelling radiance, a downwelling radiance, and/or any other suitable measurement. In some examples, step 1502 includes calibrating and/or correcting the ground-truth spectrum for dark-current contributions, radiometric factors, and/or any other relevant factors.

[0302] At step 1504, method 1500 includes acquiring first remote spectral data corresponding to the first location at substantially the time the ground-truth spectrum was measured. In other words, the first remote data is temporally

coincident with the ground-truth spectrum. The remote data comprises a spectrum measured by a device that is remote from the surface where the ground-truth sensor is deployed. For example, the remote device may comprise a satellite, a spectral sensor carried by a drone, and/or any other suitable remote device. The remote device may be hyperspectral or multispectral. In some examples, the remote device comprises a plurality of sensors having different spectral ranges, such that the plurality of devices together comprise a multispectral or hyperspectral sensor. In some examples, step 1504 includes calibrating and/or correcting the first remote spectral data for dark-current contributions, radiometric factors, and/or any other relevant factors.

[0303] At step 1506, method 1500 includes establishing a ground-truth function representing the ground-truth spectrum in a functional basis, and establishing a remote function representing the remote spectral data in the same functional basis. Establishing the respective functions includes determining respective sets of weighting coefficients associated with respective basis functions in the linear combination defining the functional-basis representation, as well as any parameters that define the basis functions themselves. As an example, the ground-truth spectrum may be represented in a radial basis function space using the following illustrative function $y(\lambda)$:

$$y(\lambda) = \sum_{i=1}^N w_i F(\|\lambda - \lambda_i\|)$$

[0304] where i is an index labeling each basis function $F(\|\lambda - \lambda_i\|)$ in the linear combination, w_i is a weighting coefficient characterizing the contribution of the i th basis function (of N total basis functions) to the representative function, and A is the wavelength of light associated with the i th basis function. An example basis function set suitable for use in this representative function are Gaussian radial basis functions $F(\|\lambda - \lambda_i\|) = e^{-(\epsilon\|\lambda - \lambda_i\|)^2}$ where ϵ is a shape parameter having any suitable value (based on, e.g., a spectral resolution of the sensor, a spectral range of the detector, and/or any other suitable factors). The remote spectral data is transformed to a representative function in the same basis space as the ground-truth spectrum (in this example, using the same Gaussian radial basis functions). In general, the respective functions representing the ground-truth spectrum and remote spectrum have different weighting coefficients.

[0305] The ground-truth spectrum and the remote spectral data may be transformed to the respective functional basis representations using any suitable method (e.g., a fitting method). Depending on the spectra and the functional basis selected, suitable methods may include regression (e.g., least-squares regression and/or any other suitable regression methods), interpolation (e.g., involving a transforming matrix), and/or any other suitable method.

[0306] At step 1508, method 1500 includes correlating the ground-truth spectrum to the first remote spectral data. Correlating the ground-truth and first remote data comprises determining a quantitative relationship (e.g., a mathematical function, a matrix transformation, a look-up table, etc.) that predicts weighting coefficients of the ground-truth function based on weighting coefficients of the remote function. In

other words, the remote coefficients are inputs to the correlating relationship, and predicted ground-truth coefficients are outputs.

[0307] Any suitable method may be used to perform the correlation. Suitable methods may include, without limitation, regression, interpolation, neural networks, etc. In some examples, performing the correlation includes using a non-linear optimization method (e.g., a regularization method) to identify a fitting function that maps the remote coefficients to ground-truth coefficients with high accuracy (e.g., with error minimized according to some predetermined scheme, such as a Tikhonov regularization).

[0308] At step 1510, method 1500 includes obtaining second remote spectral data and establishing a function representing the second remote spectral data in the functional basis space. The representative function of the second remote data is established in the same functional basis space as the functions representing the first remote data and the ground-truth data associated with the first remote data. Establishing the function representing the second remote data includes identifying weighting coefficients corresponding to basis functions within the linear combination defining the representative function.

[0309] In some examples, there is no ground-truth data corresponding to the second remote spectral data. For example, the second remote spectral data may be measured by an airborne device passing over a geographic location where no near-surface device is deployed. However, any suitable remote spectral data may be used for any suitable purpose.

[0310] At step 1512, method 1500 includes using the correlating relationship determined at step 1508 to predict, based on the weighting coefficients of the second remote-data function, estimated ground-truth weighting coefficients. The estimated ground-truth weighting coefficients define a function representing an estimated or projected ground-truth spectrum in the functional basis space. The estimated ground-truth spectrum is a prediction of a hypothetical near-surface spectrum that could have been measured at the location and time corresponding to the second remote data. Accordingly, the correlation obtained between the first ground-truth data and the first remote data is used at step 1512 to predict ground-truth data based on second remote data (e.g., remote data corresponding to a situation where ground-truth data is not available, or is available but needs to be validated, etc.).

[0311] Because the functional basis representations of the first remote data and the first ground-truth data inherently include all the data acquired in the respective measurement, the predicted ground-truth data estimated by this method tends to be more accurate and/or precise than predictions obtained by known methods. The predicted ground-truth data may be used to calculate a remote-sensing reflectance, chlorophyll concentration, nitrogen concentration, and/or any other suitable quantity, and/or used for any other suitable purpose.

P. Illustrative Combinations and Additional Examples

[0312] This section describes additional aspects and features of hyperspectral sensing systems, presented without limitation as a series of paragraphs, some or all of which may be alphanumerically designated for clarity and efficiency. Each of these paragraphs can be combined with one or more other paragraphs, and/or with disclosure from

elsewhere in this application, including the materials incorporated by reference in the Cross-References, in any suitable manner. Some of the paragraphs below expressly refer to and further limit other paragraphs, providing without limitation examples of some of the suitable combinations.

[0313] A0. A hyperspectral sensing system comprising an image sensor configured to measure an intensity of each of a plurality of spectral bands of impinging light; an optical collector configured to direct light to impinge on the image sensor; and an electronics module configured to store data corresponding to the intensity measured by the image sensor.

[0314] A1. The system of A0, wherein the optical collector includes a first aperture and a second aperture each configured to accept light; and an optical director configured to direct light accepted by the first aperture and light accepted by the second aperture to impinge on the image sensor.

[0315] A2. The system of A0, further comprising a light source, and wherein the optical collector is mounted slidably on a rail such that an angle subtended by the light source, the optical collector, and a sample object may be selectively adjusted.

[0316] B0. A hyperspectral sensing system comprising a compact spectrometer; a collector having a first aperture disposed in a first plane and configured to receive light, a second aperture disposed in a second plane and configured to receive light, and an optical director configured to direct the light received by the first and second apertures to the compact spectrometer; wherein the first and second planes are non-planar relative to each other.

[0317] B1. The system of B0, further comprising a modulator having a plurality of openings and a plurality of blocking portions, wherein the blocking portions are configured to block light.

[0318] C0. A method for simultaneously performing hyperspectral measurements on light from two sources, the method comprising receiving a first portion of light via a first entrance aperture of an optical collector; receiving a second portion of light via a second entrance aperture of the optical collector; directing the first portion of light to impinge on a sensor configured to measure wavelength-dependent intensity of impinging light; and directing the second portion of light to impinge on the sensor.

[0319] D0. A method for performing a hyperspectral fluorescence measurement, the method comprising positioning a sample, a light source, and an optical collector such that the sample, in response to illumination from the light source, emits light in a direction receivable by the optical collector; illuminating the sample using the light source; receiving light emitted by the sample using the optical collector; and measuring respective intensities of a plurality of spectral components of the received light using a sensor associated with the collector.

[0320] D1. The method of D0, wherein positioning the sample, the light source, and the optical collector includes disposing the sample and the optical collector underwater.

[0321] D2. The method of any one of D0-D1, further comprising disposing within the sample one or more tagging agents each configured to bind with a predetermined substance and to emit an identifiable wavelength-dependent fluorescence in response to illumination by the light source.

[0322] D3. The method of D2, wherein at least one of the one or more tagging agents comprises a lanthanide-based tag.

[0323] E0. Further aspects of an illustrative hyperspectral sensing system are described below:

[0324] The collector comprising a fixed aperture of 0.01 to 5 mm in between the sample and the sensor.

[0325] The collector comprising ground-glass (fused silica/SiO₂) diffuser with an entrance aperture (diffuser on sample side and aperture on sensor side).

[0326] The collector comprising an 8 degree numerical aperture SiO₂ plano convex lens between the sample and detector located at the primary focal plane.

[0327] The sensor comprising one or more dispersive elements such as prisms, waveguides, diffractive optical elements, etc.

[0328] Use of ‘multi-spectral’ (i.e. discrete wavelength band) sensors with higher number of bands (~10-30 bands)

[0329] Use of light-sensitive detectors (i.e. photodiodes) and optical color-filters or bandpass filters

[0330] Actuation, scanning or movement entire system (sensor+collector) to acquire image of scene larger than single FOV (pixel). In some examples, the collector could remain stationary relative to sensor.

[0331] Use of image stabilization technology to additionally improve acuity of image obtained on a scanning or moving platform.

[0332] Use of local storage solutions beyond non-volatile memory, flash memory, SD/micro-SD cards, etc.

[0333] Use of other data transfer technologies, as applicable, microwave, laser, etc. communication to carry out the data streaming/logging functionality.

[0334] Use of an interface for live-viewing and/or capturing the measured output (or some analysis of the measured output) on a separate handheld device (e.g. cell-phone, tablet, computer, etc.). This can be done via wired (serial, parallel) or wireless interface.

[0335] A hyperspectral sensing device mounted on a buoy, weather station, weather balloon, unmanned aerial vehicle, unmanned underwater vehicle, watercraft, aircraft, satellite, automobile, and/or any other suitable platform.

[0336] F0. An autonomous optical sensing device comprising a first spectrometer including a sensing element; an optical system configured to direct ambient light incident from a first direction onto the sensing element of the first spectrometer; and a first controller coupled to the first spectrometer and configured to automatically trigger data acquisition by the first spectrometer at selected intervals; wherein the first spectrometer and the optical system are at least partially encased in a common housing.

[0337] F1. The device of F0, wherein the optical system is further configured to direct ambient light incident from a second direction onto the sensing element of the first spectrometer.

[0338] F2. The device of F1, further comprising an optical modulator at least partially encased in the common housing, the optical modulator configured to modulate the ambient light incident from the second direction.

[0339] F3. The device of any one of F1-F2, further comprising an optical polarizer at least partially encased in the common housing, the optical polarizer configured to polarize the ambient light incident from the second direction.

[0340] F3.5 The device of F3, wherein the optical polarizer comprises a circular polarizer.

[0341] F4. The device of any one of F0-F3.5, wherein the optical system comprises a first lens assembly having a first value of a selected optical characteristic.

[0342] F5. The device of F4, wherein the first lens assembly is interchangeable with a second lens assembly having a second value of the selected optical characteristic.

[0343] F6. The device of any one of F4-F5, wherein the optical characteristic is a field of view.

[0344] F7. The device of any one of F0-F6, further comprising a second spectrometer at least partially encased in the common housing, wherein the optical system is further configured to direct ambient light incident from a second direction onto a sensing element of the second spectrometer.

[0345] F8. The device of F7, further comprising a second controller configured to automatically trigger data acquisition by the second spectrometer at selected intervals and to control transmission of data to a remote server by an onboard data processing system.

[0346] F9. The device of F8, wherein the second controller is configured to wake the data processing system from a standby mode at predetermined intervals.

[0347] F10. The device of any one of F0-F9, further comprising an optical homogenizer configured to homogenize light incident from the first direction.

[0348] F11. The device of any one of F0-F10, further comprising a photovoltaic panel configured to provide electrical power to the first controller and the first spectrometer.

[0349] F12. The device of any one of F0-F11, wherein the spectral resolution of the first spectrometer is 20 nanometers or better.

[0350] F13. The device of any one of F0-F12, further comprising at least one sensor usable for calibrating the first spectrometer.

[0351] F14. The device of F13, wherein the at least one sensor comprises a temperature sensor.

[0352] F15. A plurality of the devices of any one of F0-F14, wherein each device is in communication with a distributed computer network.

[0353] G0. A method of assessing water quality, the method comprising receiving ambient light through a first aperture of a housing of an optical device disposed adjacent a surface of a body of water, the first aperture being directed at the surface of the body of water, wherein the light received through the first aperture includes light reflected from the surface and light passing through the surface from underneath; receiving ambient light through a second aperture of the housing, the second aperture being directed at the sky, wherein the light received through the second aperture includes light coming from the sky; directing the light received through the first and second apertures into a sensing assembly disposed within the housing; sensing, using the sensing assembly, data corresponding to a spectrum of the light received through the first and second apertures; and determining, based on the sensed data, a spectrum of light originating underneath the surface of the water.

[0354] G1. The method of G0, wherein the sensing assembly comprises a first spectrometer and a second spectrometer, and directing the light received from the first and second apertures into the sensing assembly includes directing the light received through the first aperture into the first spectrometer and directing the light received through the second aperture into the second spectrometer.

[0355] G2. The method of G0, wherein the sensing assembly comprises a spectrometer, and directing the light

received through the first and second apertures into the sensing assembly includes directing the light received through the first and second apertures into the spectrometer.

[0356] G3. The method of any one of G0-G2, further comprising updating, using the recorded data, remote-sensing data of the same body of water obtained by an airborne device.

[0357] G4. The method of any one of G0-G3, wherein determining the spectrum of light originating underneath the surface of the water includes using a Mobley surface correction.

[0358] G5. The method of any one of G0-G4, wherein determining the spectrum of light originating underneath the surface of the water includes using a bidirectional reflectance distribution function.

[0359] H0. A method of assessing water quality, the method comprising receiving ambient light through a first aperture of a first optical device disposed adjacent a surface of a body of water, the first aperture being directed at the surface of the body of water at a first orientation; receiving ambient light through a second aperture of a second optical device disposed adjacent the surface, the second aperture being directed at the surface at a second orientation, wherein the light received through the first and second apertures includes light reflected from the surface and light passing through the surface from underneath; directing the light received through the first aperture into a first sensing assembly of the first device; directing the light received through the second aperture into a second sensing assembly of the second device; sensing, using the first and second sensing assemblies, data corresponding to respective spectra of the light received through the first and second apertures; detecting a total downwelling sky irradiance; and determining, based on the sensed data and the detected total downwelling sky irradiance, a spectrum of light originating underneath the surface of the water.

[0360] H1. The method of H0, wherein detecting the total downwelling sky irradiance includes using a cosine corrector.

[0361] H2. The method of any one of H0-H1, wherein the total downwelling sky irradiance is detected using the first optical device.

[0362] H3. The method of any one of H0-H1, wherein the total downwelling irradiance is detected using a third optical device.

[0363] H4. The method of any one of H0-H3, wherein the first and second orientations are each defined by a respective azimuth angle and a respective zenith angle.

[0364] H5. The method of any one of H0-H3, wherein determining the spectrum of light originating under the water includes calculating a bidirectional reflectance distribution function (BRDF) of the surface of the water; estimating, using the BRDF, the contribution of the light reflected from the surface to the data sensed by each of the sensing assemblies; and correcting the sensed data based on the estimated contributions.

[0365] H6. The method of any one of H0-H3, wherein determining the spectrum of light originating under the water includes estimating a relationship between the data sensed by each of the sensing assemblies and determining the spectrum based on the estimated relationship.

[0366] H7. The method of H6, wherein the first and second orientations are selected such that radiances of light received through the first and second apertures are approximately equal.

[0367] J0. A method for accurately measuring a spectrum of water-leaving light, the method comprising measuring a first spectrum of light corresponding to light upwelling from a surface of a body of water; predicting a theoretical upwelling spectrum using a simulation having one or more adjustable parameters; adjusting one or more of the adjustable parameters of the simulation to produce an adjusted simulation, wherein an adjusted theoretical upwelling spectrum predicted by the adjusted simulation agrees with the measured first spectrum; estimating, based on the adjusted simulation, a contribution to the measured first spectrum provided by non-water-leaving light; and subtracting the estimated contribution from the measured first spectrum to obtain a second spectrum of light corresponding to a water-leaving radiance.

[0368] J1. The method of J0, wherein measuring the first spectrum of light upwelling from the surface includes receiving the upwelling light through a first aperture of a hyperspectral sensing device disposed adjacent the surface, and measuring the first spectrum using a spectrometer of the hyperspectral sensing device.

[0369] J2. The method of J1, further comprising: measuring a third spectrum of light corresponding to light downwelling from the sky by receiving the downwelling light through a second aperture of the hyperspectral sensing device and measuring the downwelling third spectrum using the spectrometer; wherein the first aperture of the hyperspectral sensing device is directed toward the surface and the second aperture is directed toward the sky.

[0370] J3. The method of J2, further comprising calculating a remote-sensing reflectance based on the third measured spectrum of downwelling light and the second spectrum of light.

[0371] J4. The method of any one of J0-J3, wherein the simulation includes an atmospheric transfer function including at least one of the one or more adjustable simulation parameters.

[0372] J5. The method of any one of J0-J4, wherein the simulation includes a bidirectional reflectance distribution function including at least one of the one or more adjustable simulation parameters.

[0373] J6. The method of any one of J0-J5, wherein the one or more adjustable simulation parameters include an atmospheric water vapor concentration.

[0374] J7. The method of any one of J0-J6, wherein estimating the contribution of non-water-leaving light includes estimating, based on the adjusted simulation, a path-radiance spectrum.

[0375] J8. The method of any one of J0-J7, wherein the measured first spectrum includes a measured absorption line having a first absorption depth, the adjusted theoretical upwelling spectrum includes a predicted absorption line having a second absorption depth, and the second absorption depth equals the first absorption depth within a predefined tolerance.

[0376] K0. A computer-implemented method for predicting ground-truth data corresponding to remotely measured data, the method comprising: acquiring a ground-truth spectrum corresponding to light measured at a first location at a first time; acquiring first remote spectral data corresponding

to the first location at the first time; determining first weighting coefficients of a ground-truth function representing the ground-truth spectrum in a functional basis space; determining second weighting coefficients of a first remote function representing the first remote spectral data in the functional basis space; determining a correlating relationship predicting the first weighting coefficients based on the second weighting coefficients; acquiring second remote spectral data and determining third weighting coefficients of a second remote function representing the second remote spectral data in the functional basis space; and using the correlating relationship to predict, based on the third weighting coefficients, projected ground-truth weighting coefficients corresponding to a projected ground-truth function representing a projected ground-truth spectrum in the functional basis space.

[0377] K1. The method of K0, wherein the ground-truth spectrum is a hyperspectral spectrum.

[0378] K2. The method of any one of K0-K1, wherein acquiring the ground-truth spectrum comprises measuring a spectrum of light using a hyperspectral sensing device disposed at the first location at the first time.

[0379] K3. The method of any one of K0-K2, wherein the first remote spectral data comprises multi-spectral data measured by a sensor carried by a satellite.

[0380] K4. The method of any one of K0-K3, wherein the second remote spectral data corresponds to a second location different from the first location.

[0381] K5. The method of any one of K0-K4, wherein the functional basis space is defined by a set of radial basis functions.

[0382] K6. The method of K5, wherein the set of radial basis functions comprises a set of Gaussian radial basis functions.

[0383] K7. The method of any one of K0-K6, wherein determining the first weighting coefficients includes performing a least-squares regression on the ground-truth spectrum. **K8.** The method of any one of K0-K7, wherein determining the correlating relationship includes fitting the second weighting coefficients to the first weighting coefficients using Tikhonov regularization.

[0384] K9. The method of any one of K0-K8, further comprising radiometrically calibrating the ground-truth spectrum prior to determining the first weighting coefficients.

[0385] K10. The method of any one of K0-K9, further comprising computing, based on the projected ground-truth coefficients, a parameter related to water quality of a body of water associated with the second remote spectral data.

[0386] L0. A computer system for assessing water quality based on hyperspectral data, the system comprising: one or more processors; a memory; and a computer program including a plurality of instructions stored in the memory and executable by the one or more processors to: compute first weighting coefficients corresponding to a functional representation of a first spectral dataset in a functional basis; compute second weighting coefficients corresponding to a functional representation of a second spectral dataset in the functional basis; compute a quantitative operation performable on the second weighting coefficients to produce an output approximating the first weighting coefficients; perform the quantitative operation on third weighting coefficients corresponding to a functional representation of a third spectral dataset in the functional basis, thereby producing

projected fourth weighting coefficients corresponding to a functional representation of a projected fourth spectral dataset in the functional basis; and calculate at least one property related to water quality based on the projected fourth weighting coefficients.

[0387] L1. The system of L0, wherein the first spectral dataset comprises hyperspectral data acquired by a first hyperspectral sensor disposed adjacent a first surface at a first geographical location.

[0388] L2. The system of L1, wherein the first surface is a surface of a body of water.

[0389] L3. The system of any one of L1-L2, wherein the second spectral dataset comprises data measured by a second sensor remote from the first surface and the third spectral dataset comprises data measured by a third sensor remote from a second surface at a second geographical location, such that the projected fourth spectral dataset corresponds to a projected ground-truth spectral dataset corresponding to the second geographical location.

[0390] L4. The system of any one of L0-L3, wherein the at least one property related to water quality includes a chlorophyll concentration.

[0391] M0. A method for measuring a dark-current-corrected spectrum, the method comprising: measuring a first spectrum of light using a photosensitive detector having a first integration time; measuring a plurality of second spectra using the photosensitive detector, each of the second spectra corresponding to a different integration time of the photosensitive detector; estimating a respective dark-current contribution for each of the second spectra based on a respective lowest value of each of the second spectra; computing a first estimated dark-current contribution for the first spectrum based on the estimated dark-current contributions for the second spectra and the first integration time; and subtracting the first estimated dark-current contribution from each value of the first spectrum to produce a dark-current-corrected spectrum.

[0392] M1. The method of M0, wherein computing the first estimated dark-current contribution includes obtaining a quantitative function predicting dark-current contributions based on input integration times, and using the quantitative function to predict the first estimated dark-current contribution based on the first integration time.

[0393] M2. The method of M1, wherein obtaining the quantitative function includes fitting the integration times corresponding to the plurality of second spectra to the estimated dark-current contributions for the plurality of second spectra using polynomial interpolation.

[0394] M3. The method of any one of M0-M2, wherein the first spectrum and the plurality of second spectra are all measured within an interval of time, and the photosensitive detector remains deployed at an outdoor location during the interval of time.

[0395] M4. The method of M3, wherein the plurality of second spectra comprises a subset of a plurality of third spectra measured during the interval of time, the plurality of second spectra being selected from the plurality of third spectra based on respective environmental conditions corresponding to each of the second spectra.

[0396] M5. The method of M4, wherein the environmental conditions corresponding to each of the second spectra are identified based at least partially on data measured by one or more auxiliary sensors disposed in a device containing the photosensitive detector.

[0397] M6. The method of M5, wherein the auxiliary sensors include a temperature sensor.

[0398] M7. The method of any one of M0-M6, wherein the photosensitive detector comprises a spectrometer having a spectral resolution of 20 nanometers or better.

[0399] M8. The method of any one of M0-M7, wherein the photosensitive detector is deployed adjacent a body of water, the method further comprising computing, based on the dark-current-corrected spectrum, a quantity related to water quality of the body of water.

[0400] N0. A method of measuring a radiometrically calibrated spectrum using a spectral sensor deployed at an outdoor location without relocating the spectral sensor, the method comprising: measuring a spectrum of light using a spectral sensor deployed at an outdoor location; normalizing the measured spectrum using a selected normalizing factor; computing a simulated spectrum based on a simulation of at least a portion of the atmosphere at the outdoors location, the simulation including one or more adjustable parameters; adjusting at least one of the adjustable parameters to produce an adjusted simulated spectrum matching the measured spectrum according to one or more predefined criteria; determining a mathematical transformation capable of transforming the measured spectrum, such that at least a portion of the transformed measured spectrum approximates at least a portion of the adjusted simulated spectrum; and performing the mathematical transformation on the measured spectrum to produce a radiometrically calibrated spectrum.

[0401] N1. The method of N0, further comprising measuring a second spectrum using the spectral sensor deployed at the outdoor location and performing the mathematical transformation on the second spectrum to radiometrically calibrate the second spectrum.

[0402] N2. The method of any one of N0-N1, wherein a wavelength range of the simulated spectrum approximates a wavelength range of the measured spectrum.

[0403] N3. The method of any one of N0-N2, wherein the one or more predefined criteria for matching the adjusted simulated spectrum to the measured spectrum include agreement within a predefined first tolerance of a first absorption depth of a first measured absorption line of the measured spectrum and a second absorption depth of a corresponding first simulated absorption line of the adjusted simulated spectrum.

[0404] N4. The method of N3, wherein the first measured absorption line corresponds to O₂ absorption in the atmosphere.

[0405] N5. The method of any one of N3-N4, wherein the one or more predefined criteria further include agreement within a predefined second tolerance of a third absorption depth of a second measured absorption line of the measured spectrum and a fourth absorption depth of a corresponding second measured absorption line of the adjusted simulated spectrum, and wherein the first and second measured absorption lines have respective central wavelengths differing from each other by at least 40 nanometers.

[0406] N6. The method of any one of N0-N5, wherein computing the simulated spectrum includes calculating an optical thickness of an atmospheric component based on an absorption line of the measured spectrum, and using the calculated optical thickness as an initial value of one of the adjustable parameters of the simulation.

[0407] N7. The method of any one of N0-N6, further comprising correcting the measured spectrum for near-

infrared absorption by identifying a lowest value of a near-infrared portion of the measured spectrum and subtracting the lowest value from all values within the near-infrared portion.

[0408] N8. The method of any one of N0-N7, further comprising deconvolving the measured spectrum and a sensor response function of the spectral sensor prior to determining the mathematical transformation.

ADVANTAGES, FEATURES, AND BENEFITS

[0409] The different embodiments and examples of a hyperspectral sensing system described herein provide several advantages over known solutions for acquiring hyperspectral data of aquatic, aerial, and/or terrestrial environments. For example, illustrative embodiments and examples described herein allow a compact, low-weight hyperspectral sensing system having dimensions suitable for deploying on an autonomous vehicle, a remotely operated vehicle, and/or an unmanned aerial vehicle.

[0410] Additionally, and among other benefits, illustrative embodiments and examples described herein allow a hyperspectral sensing device that can be deployed autonomously, without power cables or data cables.

[0411] Additionally, and among other benefits, illustrative embodiments and examples described herein allow a hyperspectral sensing device that is relatively insensitive to vibrations (e.g., due to use of a compact spectrometer).

[0412] Additionally, and among other benefits, illustrative embodiments and examples described herein allow a hyperspectral sensing device to be constructed using a relatively inexpensive compact spectrometer, enabling a network of hyperspectral sensing devices to be deployed at relatively low overall cost.

[0413] Additionally, and among other benefits, illustrative embodiments and examples described herein allow a simultaneous or near-simultaneous measurement of sky radiance, upwelling water radiance, and optionally radiance of light reflected from a reference plaque. The ability to make these measurements simultaneously or nearly simultaneously increases the accuracy and precision of the measurements and any quantities inferred from the measurements, such as remote-sensing reflectance.

[0414] Additionally, and among other benefits, illustrative embodiments and examples described herein allow hyperspectral measurements in underwater environments, above-water environments, and aerial environments using the same hyperspectral sensing device, which may enable consistency among measurements performed in these different environments. Additionally, the ability to perform measurements in these different environments using just one device decreases the amount of equipment that must be transported to measurement sites (e.g., carried on watercraft, buoys, drones, and/or manually carried by personnel).

[0415] Additionally, and among other benefits, illustrative embodiments and examples described herein allow hyperspectral measurements to be made using a device having a wider dynamic range than known hyperspectral sensors, such that a single device is configured to acquire hyperspectral data when deployed underwater and when deployed above water.

[0416] Additionally, and among other benefits, illustrative embodiments and examples described herein allow a hyperspectral sensing system to autonomously trigger data col-

lection or adjust measurement parameters based on sensed data such as temperature, pressure, time, location, light levels, salinity, etc.

[0417] Additionally, and among other benefits, illustrative embodiments and examples described herein allow collection optics on a hyperspectral sensing system to be adjusted and/or replaced without adjustment to any sensors (e.g., spectrometers).

[0418] Additionally, and among other benefits, illustrative embodiments and examples described herein allow hyperspectral measurements of fluorescence, scattering, and/or absorption.

[0419] No known system or device can perform these functions. However, not all embodiments and examples described herein provide the same advantages or the same degree of advantage.

CONCLUSION

[0420] The disclosure set forth above may encompass multiple distinct examples with independent utility. Although each of these has been disclosed in its preferred form(s), the specific embodiments thereof as disclosed and illustrated herein are not to be considered in a limiting sense, because numerous variations are possible. To the extent that section headings are used within this disclosure, such headings are for organizational purposes only. The subject matter of the disclosure includes all novel and nonobvious combinations and subcombinations of the various elements, features, functions, and/or properties disclosed herein. The following claims particularly point out certain combinations and subcombinations regarded as novel and nonobvious. Other combinations and subcombinations of features, functions, elements, and/or properties may be claimed in applications claiming priority from this or a related application. Such claims, whether broader, narrower, equal, or different in scope to the original claims, also are regarded as included within the subject matter of the present disclosure.

What is claimed is:

1. A method of measuring a radiometrically calibrated spectrum using a spectral sensor deployed at an outdoor location without relocating the spectral sensor, the method comprising:

- measuring a spectrum of light using a spectral sensor deployed at an outdoor location;
- normalizing the measured spectrum using a selected normalizing factor;
- computing a simulated spectrum based on a simulation of at least a portion of the atmosphere at the outdoors location, the simulation including one or more adjustable parameters;
- adjusting at least one of the adjustable parameters to produce an adjusted simulated spectrum matching the measured spectrum according to one or more predefined criteria;
- determining a mathematical transformation capable of transforming the measured spectrum, such that at least a portion of the transformed measured spectrum approximates at least a portion of the adjusted simulated spectrum; and
- performing the mathematical transformation on the measured spectrum to produce a radiometrically calibrated spectrum.

2. The method of claim 1, further comprising measuring a second spectrum using the spectral sensor deployed at the

outdoor location and performing the mathematical transformation on the second spectrum to radiometrically calibrate the second spectrum.

3. The method of claim 1, wherein the one or more predefined criteria for matching the adjusted simulated spectrum to the measured spectrum include agreement within a predefined first tolerance of a first absorption depth of a first measured absorption line of the measured spectrum and a second absorption depth of a corresponding first simulated absorption line of the adjusted simulated spectrum.

4. The method of claim 3, wherein the one or more predefined criteria further include agreement within a predefined second tolerance of a third absorption depth of a second measured absorption line of the measured spectrum and a fourth absorption depth of a corresponding second measured absorption line of the adjusted simulated spectrum, and wherein the first and second measured absorption lines have respective central wavelengths differing from each other by at least 40 nanometers.

5. The method of claim 1, wherein computing the simulated spectrum includes calculating an optical thickness of an atmospheric component based on an absorption line of the measured spectrum, and using the calculated optical thickness as an initial value of one of the adjustable parameters of the simulation.

6. The method of claim 1, further comprising correcting the measured spectrum for near-infrared absorption by identifying a lowest value of a near-infrared portion of the measured spectrum and subtracting the lowest value from all values within the near-infrared portion.

* * * * *